



## MD520 Series General-Purpose AC Drive Safety Function Guide



Industrial  
Automation



Intelligent  
Elevator



New Energy  
Vehicle



Industrial  
Robot



Rail  
Transit



Data code 19011795 A02  
<Original instructions>

# Preface

## Introduction

The MD520 series general-purpose AC drive developed by Inovance provides high-performance current vector control. It is designed to control and regulate the speed and torque of three-phase AC asynchronous motors. The AC drive can be used to drive a variety of automated production equipment, such as textile machines, paper machines, wire drawing machines, machine tools, packaging machines, food machines, fans, and water pumps.

The MD520 series AC drive can implement the STO safety function and control the safety function through an external terminal (referred to as a local trigger in this document). This guide presents the safety information, instructions for mechanical and electrical installation, commissioning and maintenance guidance, and safety-related parameters of the AC drive.

## More Documents

| Name   | Data Code | Description  |
|--|-----------|--|
| MD520 Series AC Drive Safety Function Guide (this document)      | 19011795  | Presents the safety information, instructions for mechanical and electrical installation, commissioning and maintenance guidance, and safety-related parameters of the AC drive.   |
| MD520 Series AC Drive Quick Installation and Commissioning Guide | 19011712  | Presents the installation, wiring, commissioning, troubleshooting, parameters, and fault codes of the AC drive.  |
| MD520 Series AC Drive Hardware Guide                             | 19011713  | Presents the composition, technical specifications, components, dimensions, options (including installation accessories, cables, and peripheral electrical components), and extension cards of the AC drive, as well as routine maintenance and repair, and certification and standard compliance of the AC drive. |
| MD520 Series AC Drive Installation Guide                         | 19011714  | Presents the installation dimensions, space design, specific installation steps, wiring requirements, routing requirements, and option installation requirements of the AC drive, as well as solutions to common EMC problems.   |
| MD520 Series AC Drive Commissioning Guide                        | 19011715  | Presents the software tools, processes, and specific steps of commissioning of the AC drive, as well as troubleshooting, fault codes, and parameters related to the AC drive.  |

| Name                                      | Data Code | Description   |
|---|-----------|---|
| MD520 Series AC Drive Communication Guide | 19011716  | Presents the communication modes, networking, and communication settings of the AC drive.       |
| MD520 Series AC Drive Function Guide      | 19011717  | Presents the function applications, communication, fault codes, and parameters of the AC drive. |

## Revision History

| Date of Revision | Version | Description  |
|------------------|---------|--|
| June 2022        | A00     | First release  |
| September 2022   | A01     | In section 1.3, add "IEC61800-5-2:2016 in second environment". |
| October 2022     | A02     | Update the note on page 16.                                    |

# Table of Contents

|   |    |
|---|----|
| Preface .....   | 1  |
| Safety Precautions .....                                | 5  |
| 1 General .....   | 11 |
| 1.1 STO Safety Function .....                           | 11 |
| 1.2 Terms and Abbreviations .....                       | 11 |
| 1.3 Safety Standards .....                              | 11 |
| 1.4 Precautions for Use .....                           | 12 |
| 2 Product Information .....                             | 17 |
| 2.1 Nameplate and Model Number .....                    | 17 |
| 2.2 Cable Models .....                                  | 18 |
| 2.2.1 Main Circuit Cables .....                         | 18 |
| 2.2.2 Selection of Control Circuit Cables .....         | 26 |
| 3 Components .....                                      | 27 |
| 3.1 Overview .....                                      | 27 |
| 3.2 Components of T1 to T6 Models .....                 | 27 |
| 3.3 Components of T7 to T9 Models .....                 | 29 |
| 3.4 Components of T10 to T12 Models .....               | 30 |
| 4 Operating Panel .....                                 | 32 |
| 4.1 LED Operating Panel .....                           | 32 |
| 5 Installation .....                                    | 39 |
| 5.1 Personnel .....                                     | 39 |
| 5.2 Environment .....                                   | 39 |
| 5.3 Clearance .....                                     | 40 |
| 5.4 Tools .....   | 43 |
| 5.5 Unpacking and Transportation .....                  | 45 |
| 5.5.1 Package Check .....                               | 45 |
| 5.5.2 Transportation Before Unpacking .....             | 50 |
| 5.5.3 Transportation and Hoisting After Unpacking ..... | 51 |
| 5.5.4 Unpacking .....                                   | 53 |
| 5.5.5 Storage .....                                     | 54 |
| 5.6 Cable Preparation .....                             | 54 |
| 5.7 Mechanical Installation .....                       | 54 |
| 5.7.1 Installation Methods .....                        | 54 |
| 5.7.2 Inspection Before Installation .....              | 55 |
| 5.7.3 Installing the AC Drive .....                     | 55 |

|         |  |     |
|---------|--|-----|
| 5.7.3.1 | Backplate Mounting . . . . .                         | 55  |
| 5.7.3.2 | Through-Hole Mounting . . . . .                      | 57  |
| 5.7.3.3 | Installation in a Cabinet . . . . .                  | 60  |
| 5.7.4   | Inspection After Installation . . . . .              | 65  |
| 5.8     | Electrical Installation . . . . .                    | 65  |
| 5.8.1   | Inspection Before Wiring . . . . .                   | 65  |
| 5.8.2   | Main Circuit Terminals . . . . .                     | 66  |
| 5.8.3   | Control Circuit Terminals. . . . .                   | 68  |
| 5.8.4   | Inspection After Wiring . . . . .                    | 73  |
| 5.8.5   | Electrical Wiring Diagram. . . . .                   | 74  |
| 6       | Wiring. . . . .                                      | 76  |
| 6.1     | Safety Cautions . . . . .                            | 76  |
| 6.2     | STO Terminals (J14) and Wiring. . . . .              | 77  |
| 7       | Safety Function . . . . .                            | 80  |
| 7.1     | Safety Function Overview . . . . .                   | 80  |
| 7.2     | Parameter Settings. . . . .                          | 80  |
| 7.3     | STO. . . . .   | 80  |
| 7.3.1   | Overview . . . . .                                   | 80  |
| 7.3.2   | Triggering STO in Local Mode . . . . .               | 81  |
| 7.3.3   | Time Sequence Diagram . . . . .                      | 81  |
| 8       | Commissioning, Operation, and Maintenance. . . . .   | 83  |
| 8.1     | Commissioning, Operation, and Maintenance. . . . .   | 83  |
| 9       | Maintenance. . . . .                                 | 88  |
| 9.1     | Routine Maintenance . . . . .                        | 88  |
| 9.1.1   | Daily Inspection Items . . . . .                     | 88  |
| 9.1.2   | List of Periodic Inspection Items. . . . .           | 89  |
| 9.2     | Main Circuit Insulation Test . . . . .               | 90  |
| 9.3     | Replacement of Quick-Wear Parts. . . . .             | 91  |
| 9.3.1   | Service Life of Quick-Wear Parts . . . . .           | 91  |
| 9.3.2   | Replacing the Cooling Fan . . . . .                  | 91  |
| 9.3.3   | Replacing the Filter Electrolytic Capacitor. . . . . | 98  |
| 9.4     | Storage and Warranty . . . . .                       | 98  |
| 10      | Troubleshooting . . . . .                            | 100 |
| 10.1    | Troubleshooting . . . . .                            | 100 |

# Safety Precautions

## Safety disclaimer

1. This section presents essential safety instructions for proper use of the equipment. Before operating the equipment, read through the user guide and comprehend all the safety instructions. Failure to comply with the safety instructions may result in damage to equipment, severe injuries, or even death.
2. "CAUTION", "WARNING", and "DANGER" messages in the guide are supplementary only and do not cover all safety precautions.
3. Use the AC drive according to the designated environment requirements. Damage caused by improper use is not covered by warranty.
4. Inovance shall take no responsibility for any physical injuries or property damage caused by improper use.

## Safety levels and definitions



Indicates that failure to comply with the notice will result in severe injuries or even death.



Indicates that failure to comply with the notice may result in severe injuries or even death.



Indicates that failure to comply with the notice may result in minor injuries or equipment damage.

## Safety precautions

- Some drawings in this guide show the equipment without covers or protective guards to display more details. Be sure to install the covers and protective guards before using the equipment and operate it in accordance with the instructions.
- Product drawings in this guide are for reference only and may be slightly different from the product you ordered.

### Unpacking and Acceptance



- Do not install the equipment if you find damage, rust, or signs of use on the equipment or its accessories upon unpacking.
- Do not install the equipment in case of water seepage in the equipment, part missing or part damage.
- Do not install the equipment if the packing list does not match the product you received.

 **CAUTION**

- Before unpacking, check whether the packing is intact without damage, water seepage, damp, and deformation.
- Unpack the package by following the unpacking sequence. Do not strike the package violently.
- When unpacking, check the surface of the equipment and accessories for damage, rust, and scratches.
- After unpacking, check the equipment, accessories, and materials in the package against the packing list.

**Storage and Transportation**

 **WARNING**

- Use specialized hoisting equipment and qualified staff to move large-scale or heavy equipment. Failure to comply may result in physical injuries or equipment damage.
- Before hoisting the equipment, ensure that the equipment components such as the front cover and terminal blocks are secured firmly with screws. Loosely-connected components may fall off and result in physical injuries or equipment damage.
- Never stand or stay below a lifted or hoisted equipment.
- When lifting the equipment with a steel wire rope, lift it steadily at a constant rate to prevent it from vibration, shock, and turnover. Do not keep the equipment lifted for a long time. Failure to comply may result in injuries or equipment damage.

 **CAUTION**

- Handle the equipment with care and mind your steps. Failure to comply may result in physical injuries or equipment damage.
- When carrying the equipment with bare hands, hold the equipment casing firmly with care to prevent parts from falling. Failure to comply may result in physical injuries.
- Store and transport the equipment in strict accordance with the storage and transportation requirements. Failure to comply will result in equipment damage.
- Avoid storing or transporting the equipment in environments with water splash, rain, direct sunlight, strong electric field, strong magnetic field, and strong vibration.
- Avoid storing the equipment for more than 3 months. Long-term storage requires stricter protection and necessary inspections.
- Pack the equipment strictly before transportation. Use a sealed box for long-distance transportation.
- Never transport the equipment with other equipment or materials that may harm or have negative impacts on it.

**Installation**

 **DANGER**

- Operations must be carried out by professionals who have received necessary electrical training. Operations by non-professionals are strictly prohibited.

**WARNING**

- Read through the guide and safety precautions before installation.
- Do not install this equipment in places with strong electric or magnetic fields.
- Before installation, make sure that the installation position is mechanically strong enough to bear the weight of the equipment. Failure to comply may result in mechanical hazards.
- Do not wear loose clothes or accessories during installation. Failure to comply may result in electric shock.
- When the equipment is installed in an enclosed environment (such as a cabinet or casing), ensure adequate cooling of the environment by using cooling devices (such as a fan or an air conditioner). Failure to comply may result in equipment over-temperature or fire.
- Do not modify the equipment.
- Do not fiddle with the bolts used to fix equipment components or the bolts marked in red.
- When the equipment is installed in a cabinet or final assembly, provide a fireproof enclosure that provides adequate electrical and mechanical protection conforming to relevant IEC standards and local laws and regulations.
- Before installing equipment with strong electromagnetic interference, such as a transformer, install an electromagnetic shielding device for this equipment to prevent malfunctions.
- Install the equipment onto an incombustible object such as metal. Keep the equipment away from combustible objects. Failure to comply will result in fire.

**CAUTION**

- Cover the top of the equipment with cloth or paper during installation to prevent unwanted objects such as metal chippings, oil, and water from falling into the equipment and causing faults. After installation, remove the cloth or paper to prevent over-temperature caused by poor ventilation due to blocked ventilation holes.
- Resonance may occur when a machine supposed to run at a constant speed is running at variable speeds. In this case, place anti-vibration rubber under the motor frame or use the vibration suppression function to reduce resonance.

**Wiring****DANGER**

- Never allow non-qualified personnel to install, wire, inspect or maintain the equipment or replace any parts of the equipment.
- Before wiring, cut off all equipment power supplies. Wait for at least the time specified on the equipment warning label after power-off so that residual voltage can discharge safely. Measure the DC voltage on the main circuit to ensure that it is within the safe voltage range. Failure to comply may result in electric shock.
- Do not perform wiring, remove the equipment cover, or touch the circuit board when power is on. Failure to comply will result in electric shock.
- Make sure that the AC drive and related equipment are properly grounded. Failure to comply may result in electric shock.





**WARNING**

- Never connect the input power cable to output terminals of the product or other equipment. Failure to comply may result in equipment damage or even fire.
- When connecting a drive to a motor, ensure consistency of terminal phase sequences between the drive and the motor to prevent reverse motor rotation.
- Use cables with required diameter and shield. Properly ground one end of the shield if a shielded cable is used.
- Tighten terminal screws with tightening torque specified in this guide. Failure to comply may result in overheat and damage to the connection parts or even fire.
- After wiring, ensure that all cables are connected properly and no screws, washers, or exposed cables are left inside the equipment. Failure to comply may result in electric shock or equipment damage.



**CAUTION**

- During wiring, follow the proper electrostatic discharge (ESD) procedures, and wear an antistatic wrist strap. Failure to comply will result in damage to internal equipment circuits.
- Use shielded twisted pairs for the control circuit. Connect the shield to the grounding terminal of the equipment. Failure to comply will result in equipment malfunction.

**Power-on**



**DANGER**

- Before power-on, make sure that the equipment is installed properly with reliable wiring and the motor can be restarted.
- Before power-on, ensure that the power supply meets requirements. Failure to comply may result in equipment damage or even fire.
- After power-on, do not open the cabinet door or protective cover, touch any terminal, or dismantle any device or components. Failure to comply may result in electric shock.



**WARNING**





- After wiring and parameter setting, carry out a trial run to ensure safe and proper functioning of the equipment. Failure to comply may result in physical injuries or equipment damage.
- Before power-on, make sure that the voltage of the power supply matches the rated voltage of the equipment. Using an improper voltage may result in fire.
- Before power-on, ensure that no one is near the equipment, motor, or machine. Failure to comply may result in physical injuries or even death.

**Operation**



**DANGER**

- Never allow non-qualified personnel to operate the equipment. Failure to comply may result in physical injuries or even death.
- Do not touch any connecting terminals or disassemble any unit or component of the equipment during operation. Failure to comply will result in electric shock.

|  |
|--|
| <div data-bbox="191 132 340 177" style="border: 1px solid black; padding: 2px; display: inline-block;">  <b>WARNING</b> </div> <ul style="list-style-type: none"> <li>• Do not touch the housing, fan, or resistor of the equipment to check temperature. Failure to comply may result in burns.</li> <li>• During operation, prevent metal and other foreign objects from falling into the equipment. Failure to comply may result in fire or equipment damage.</li> </ul>   |
| <b>Maintenance</b>   |
| <div data-bbox="191 341 340 386" style="border: 1px solid black; padding: 2px; display: inline-block;">  <b>DANGER</b> </div> <ul style="list-style-type: none"> <li>• Never allow non-qualified personnel to install, wire, inspect or maintain the equipment or replace any parts of the equipment.</li> <li>• Never carry out maintenance when power is on. Failure to comply may result in electric shock.</li> <li>• Before maintenance, cut off all equipment power supplies and wait at least a period of time specified on the equipment warning label.</li> <li>• In case of a permanent magnet motor, do not touch the motor terminals immediately after power-off because the motor terminals will generate induced voltage during rotation even after the equipment power supply is cut off. Failure to comply may result in electric shock.</li> </ul>   |
| <div data-bbox="191 670 340 715" style="border: 1px solid black; padding: 2px; display: inline-block;">  <b>WARNING</b> </div> <ul style="list-style-type: none"> <li>• Perform routine and periodic inspection and maintenance on the equipment according to maintenance requirements and keep a maintenance record.</li> </ul>  |
| <b>Repair</b>  |
| <div data-bbox="191 829 340 874" style="border: 1px solid black; padding: 2px; display: inline-block;">  <b>DANGER</b> </div> <ul style="list-style-type: none"> <li>• Never allow non-qualified personnel to install, wire, inspect or maintain the equipment or replace any parts of the equipment.</li> <li>• Do not repair the equipment when power is on. Failure to comply may result in electric shock.</li> <li>• Before inspection or repair, cut off all equipment power supplies and wait at least a period of time specified on the equipment warning label.</li> </ul>   |
| <div data-bbox="191 1059 340 1104" style="border: 1px solid black; padding: 2px; display: inline-block;">  <b>WARNING</b> </div> <ul style="list-style-type: none"> <li>• Require for repair services according to the equipment warranty agreement.</li> <li>• When the fuse is blown or the circuit breaker or earth leakage current breaker (ELCB) trips, wait for at least the time designated on the equipment warning label before power-on or further operations. Failure to comply may result in death, physical injuries, or equipment damage.</li> <li>• When the equipment fails or is damaged, arrange for qualified technicians to troubleshoot and repair the equipment in accordance with the maintenance instructions and retain a maintenance record.</li> <li>• Replace quick-wear parts of the equipment according to the replacement instructions.</li> <li>• Do not use damaged equipment. Failure to comply may result in death, physical injuries, or severe equipment damage.</li> <li>• After replacing equipment, make sure to re-check wiring and parameter settings.</li> </ul> |

| <b>Disposal</b>  |
|--|
| <div style="display: flex; align-items: center;">  <div style="margin-left: 10px;"><b>WARNING</b></div> </div> <ul style="list-style-type: none"> <li>• Dispose of retired equipment in accordance with local regulations and standards. Failure to comply may result in property damage, physical injuries, or even death.</li> <li>• Recycle retired equipment in accordance with waste disposal standards of the industry to avoid environmental pollution.</li> </ul> |

### Safety labels

For safe equipment operation and maintenance, comply with the safety labels on the equipment. Do not damage or remove the safety labels. See the following table for descriptions of the safety labels.

| <b>Safety Label</b>   | <b>Description</b>   |
|---|--|
|  | <ul style="list-style-type: none"> <li>• Read through the safety instructions before operating the equipment. Failure to comply may result in equipment damage, physical injuries, or even death.</li> <li>• Do not touch terminals or remove the cover when power is on or within 10 minutes after power is cut off. Failure to comply may result in electric shock.</li> </ul> |

# 1 General

## 1.1 STO Safety Function

### Safety function for safety drives

- STO  
The Safe Torque Off (STO) function immediately blocks the motor torque or power output in electronic mode according to input signals from external devices. This function complies with stop category 0 in EN 60204-1. If the motor is still rotating when the STO function is enabled, the motor will coast to a standstill.

## 1.2 Terms and Abbreviations

| Term/Abbr.     | Description  |
|----------------|--|
| Cat.           | Category of safety components in the control system. The categories are B, 1, 2, 3, and 4. |
| DCavg          | Average diagnostic coverage (%)  |
| DTI            | Diagnostic test interval   |
| SFF            | Safe failure fraction  |
| PFHd           | Probability of dangerous failure on demand per hour  |
| PL             | Performance level  |
| SC             | System capability  |
| SIL            | Safety integrity level   |
| T <sub>1</sub> | Proof test interval  |
| DI             | Digital input  |
| DO             | Digital output   |
| MTTFd          | Mean time to dangerous failure   |

## 1.3 Safety Standards

### Standards compliance

- North American standards (UL)  
UL 61800-5-1  
CSA C22.2 No. 274
- EC directives and standards  
Low Voltage Directive 2014/35/EU Standard EN 61800-5-1  
EMC Directive 2014/30/EU Standard EN 61800-3

Machinery Directive 2006/42/EC  
(functional safety) Standard IEC61800-5-2 in second environment

- Safety standards

| Model     | Safety Standard   | Reference   |
|-----------|-------------------|---|
| MD520**** | Functional safety | IEC 61508:2010<br>ISO 13849-1:2015<br>ISO 13849-2:2012<br>IEC 62061:2021<br>IEC 61800-3:2017<br>EN 61508:2010<br>EN ISO 13849-1:2015<br>EN ISO 13849-2:2012<br>EN IEC 62061:2021<br>EN IEC 61800-3:2018 |
|           | EMC               | IEC 61000-6-7:2014<br>IEC 61326-3-1:2017<br>IEC 61800-5-2:2016<br>IEC 61800-3:2017<br>EN 61000-6-7:2015<br>EN 61326-3-1:2017<br>EN 61800-5-2:2017<br>EN IEC 61800-3:2018                                |
|           | LVD               | IEC 61800-5-1:2007/AMD1:2016<br>EN 61800-5-1:2007/A1:2017   |

- Safety data

| Item                            | Safety Data                      |
|---------------------------------|----------------------------------|
| SIL                             | SIL3, IEC61508                   |
| PFHd                            | 3.13E-09, 3.1% of SIL3, IEC61508 |
| Cat.                            | 3, EN ISO 13849-1                |
| PL                              | e, EN ISO 13849-1                |
| MTTFd                           | 326 years (high)                 |
| DCavg                           | ≥ 90% (medium)                   |
| T <sub>1</sub>                  | 20 years                         |
| HFT                             | 1                                |
| SC                              | SC3                              |
| Application mode                | High demand or continuous mode   |
| Response time (nominal voltage) | ≤ 20 ms                          |

## 1.4 Precautions for Use

### Safety precautions



This section describes warning symbols used for safety functions and provides safety instructions to be observed during installation and maintenance of safety modules for

the drive or inverter. Failure to comply with the safety precautions may result in damage to equipment, physical injuries, or even death. Read this section before starting installation.

The figures, pictures, and examples in this guide are for reference only, and may not be applicable to all products covered by this guide.

As products and documentation upgrade, the specifications described in the safety function section may be modified without advanced notice.

Table 1–1 Warning symbols

| Symbol  | Text    | Description                        | Consequence  |
|---|---------|------------------------------------|--|
| Example:<br><br>DANGER<br><br>Hazardous voltage | DANGER  | Critical risk                      | Ignoring the warning will lead to severe injuries or even death.     |
|   | WARNING | Major risk                         | Ignoring the warning may lead to severe injuries or even death.      |
|   | CAUTION | Minor risk                         | Ignoring the warning may lead to minor injuries.                     |
| Electric shock<br>   | STOP!   | Damage to equipment or environment | Ignoring the warning may lead to damage to equipment or environment. |

## Note

- Users must incorporate safety measures in system design and electrical installation for both normal operation and troubleshooting.
- The design, installation, commissioning, and maintenance of the system must be implemented by trained and experienced professionals. They should read the operation guide and related safety information.

Anyone using the safety function must observe current mechanical criteria. Before putting a machine onto the market, the manufacturer or its licensor is obliged to carry out hazard analysis (in accordance with applicable mechanical criteria), take appropriate measures to reduce or eliminate relevant hazards, and select compliant elements based on the hazard analysis result.

The following describes the information required before starting operation.

- Before operation, read the following safety precautions, risk assessment information, and restriction information.

- Before using the safety function, properly understand all the related information.
- 

## **Note**

If the safety function is used incorrectly or the safety function does not meet safety requirements at the site, physical injuries may arise.

---

## **Safety measures**

Carefully read and observe the following important precautions when using the safety function:

- The STO function is not a substitute for the emergency stop (E-stop) function. If only the STO function is triggered, with no extra measures taken, and the power supply cannot be cut off in emergency, high-voltage parts of the motor and drive are still energized. This may incur the risk of electric shock or other electricity-related risks. Therefore, carry out maintenance of electrical parts of the drive or motor only after isolating the drive system from the main power supply.
- Depending on standards and requirements for particular applications, STO may be used as part of an E-stop system. However, different from the E-stop function, STO is designed for use in a dedicated safety control arrangement whose purpose is to prevent hazards from occurring.
- The E-stop function is typically provided in a machine to allow operators to notice unexpected situations and take actions to prevent accidents.
- The design requirements for E-stop are different from safety interlock. Generally, E-stop shall be independent from any complex or intelligent control. It may use purely electromechanical devices to disconnect the power supply or initiate a controlled rapid stop using other means such as dynamic or regenerative braking.



- The design of safety-related systems requires specialist knowledge. To ensure the safety of the entire control system, it is necessary to design the entire system according to recognized safety rules. An individual subsystem with the STO function, although intentionally designed for safety-related applications, cannot ensure the safety of the entire system.
  - In emergency stop situations, the STO function can be used to stop the drive.
  - In processes without personnel protection, do not use the STO function to stop the drive. If the STO function is used to stop a running drive, the drive will coast to stop. If this is unacceptable, stop the system using a proper mode instead of the STO function.
  - This publication provides a guide on the application of Inovance STO function and also on the design of safety-related systems for machinery control.
  - It is the responsibility of the designer of the end product or application to ensure safety and compliance with relevant regulations.
- 

### Risk assessment

- Before using the safety function, perform risk assessment on the drive system in advance to ensure compliance with the standard safety integrity level.
  - The following residual risks can be present even when the safety function is operating. Therefore, safety must always be considered during risk assessment.
  - If external forces (such as gravity on the vertical axis) are applied when the safety function is operating, the motor will rotate due to these external forces. In this case, provide a separate mechanical brake to secure the motor.
- 

### Note

- When multiple faults occur on the IGBT power transistor, the drive will produce an aligning torque regardless of whether the STO function is used. This torque may drive the motor shaft to rotate to a maximum angle of  $(180 \div p)$ .
  - $p$  indicates the number of motor pole pairs.
- 

To guarantee safety, users must determine all the assessed risks and residual risks of the integrated equipment. Companies and individuals that establish safety-related systems must be solely responsible for system installation and commissioning. In addition, relevant sub-systems subject to the European Machinery Directive must be certified against safety standards, and risks and safety levels must be assessed for the machine or the entire system.



The following describes the residual risks related to the safety function of this equipment.

**Common residual risks**

- Before shipping the equipment to end users, check the settings of safety-related parts using the programming tool and the display. Record and save the settings related to the safety monitoring function and the programming tool that you use. Use a checklist during this process.
- Safety rests with proper installation, wiring, and tuning. Follow instructions in the safety guide during installation, wiring, and commissioning.
- Installation, trial run, repair, and commissioning must be carried out by skilled personnel only. Only relevant safety engineers are allowed to install and operate the equipment.
- Separate the wiring for the safety function from other signal wiring.
- Protect cables using proper methods (such as using cable guards when routing in a cabinet).
- Use switches, relays, and sensors that comply with safety standards. If switches, relays, or sensors that do not comply with safety standards are used, verify the safety.
- Reserve adequate clearances or creepage distances based on the voltage used.
- The time error in safety monitoring depends on parameter settings.
- **STO**  
This function cuts off only the motor torque but not the drive power supply. Before drive maintenance, cut off the power supply to the drive and confirm that the drive is de-energized.

---

**Note**

Power on to reset the AC drive, and then trigger the STO function at least once every three months.

---

## 2 Product Information

### 2.1 Nameplate and Model Number

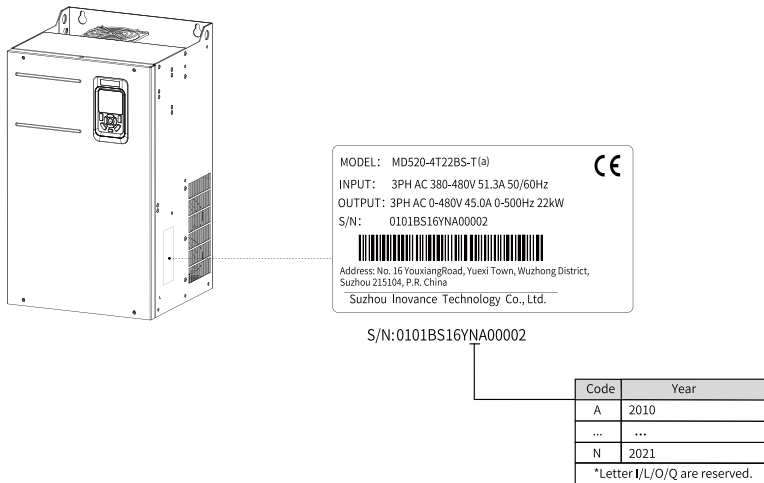

Figure 2-1 Nameplate and designation rules

|   |   |   |   |
|---|---|---|---|
| ① | <b>Product name</b><br>MD520: AC drive series   | ⑥ | <b>Reactor</b><br>Null: See the description below.<br>-T: A DC reactor is provided, and it is applicable to the T5 models.<br>-L: An output AC reactor is provided, and it is applicable to the T10 to T12 models.              |
| ② | <b>Voltage class</b><br>4T: Three-phase 380 V to 480 V<br>2T: Three-phase 200 V to 240 V<br>2S: Single-phase 200 V to 240 V |   |   |
| ③ | <b>Power rating (kW)</b><br>0.4: 0.4<br>...<br>400: 400   | ⑦ | <b>Customer identity</b><br>Null: Not provided<br>(a): The model number may include a suffix “XXXXXXXXXX”, Where “XXXXXXXXXX” can be blank or combination of any alphanumeric and/or symbols that represents customer identity. |
| ④ | <b>Braking unit</b><br>Null: Not provided<br>B: Provided  |   |   |
| ⑤ | <b>Safety function</b><br>Null: Not provided<br>S: STO function provided  |   |   |

---

## Note

- For three-phase 380 V to 480 V drives, reactors are not supported by T1 to T4 models, whereas the DC reactor is optional for T5 models and standard for T6 models and above.
  - For three-phase 380 V to 480 V drives, the braking unit is standard for T1 to T4 models and optional for T5 to T8 models.
- 

## 2.2 Cable Models

### 2.2.1 Main Circuit Cables

#### Power cable selection

Observe national or regional regulations when selecting power cables. IEC cables must meet the following requirements:

- EN 60204-1 and IEC 60364-5-52 standards
- PVC cable with copper conductors
- Withstanding 40°C ambient temperature and 70°C cable surface temperature (Note: Contact the manufacturer if the ambient temperature exceeds 40°C.)
- Symmetrical cables with copper mesh shield

If the recommended cable specifications for peripheral devices or optional parts exceed the applicable cable specification range, contact Inovance.

To comply with the EMC standards, use shielded cables. Shielded cables are classified into the three-conductor cables and four-conductor cables, as shown in the following figure. If a three-conductor cable is used but its shield cannot provide sufficient conductivity, add an independent PE cable. Alternatively, use a four-conductor cable containing a PE conductor. To suppress radio frequency interference effectively, use coaxial copper braid as the cable shield. Ensure that the braided density is greater than 90% to enhance the shielding performance and conductivity.

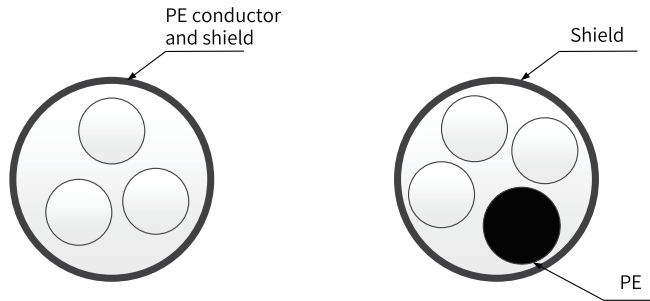

Figure 2-2 Recommended power cable types

## Recommended cables

Table 2-1 Cable selection (three-phase 380 V to 480 V)

| Structure | Model                | RST/UWV                            |           | Ground Cable                       |           | Screw | Tightening Torque<br>N·m<br>(lb.in) |
|-----------|----------------------|------------------------------------|-----------|------------------------------------|-----------|-------|-------------------------------------|
|           |                      | Cable Size<br>(mm <sup>2</sup> <1> | Cable Lug | Cable Size<br>(mm <sup>2</sup> <1> | Cable Lug |       |                                     |
| T1        | MD520-4T0.4B(S)      | 3 x 0.75                           | TNR0.75-4 | 0.75                               | TNR5.5-5  | M4    | 1.2<br>(10.6)                       |
|           | MD520-4T0.7B(S)      | 3 x 0.75                           | TNR0.75-4 | 0.75                               | TNR8-5    | M4    |                                     |
|           | MD520-4T1.1B(S)      | 3 x 0.75                           | TNR0.75-4 | 0.75                               | TNR5.5-5  | M4    |                                     |
|           | MD520-4T1.5B(S)      | 3 x 0.75                           | TNR0.75-4 | 0.75                               | TNR8-5    | M4    |                                     |
|           | MD520-4T2.2B(S)      | 3 x 0.75                           | TNR0.75-4 | 0.75                               | TNR5.5-5  | M4    |                                     |
|           | MD520-4T3.0B(S)      | 3 x 1.5                            | TNR1.25-4 | 1.5                                | TNR8-5    | M4    |                                     |
| T2        | MD520-4T3.7B(S)      | 3 x 2.5                            | TNR2-4    | 2.5                                | TNR5.5-5  | M4    | 2.8<br>(24.8)                       |
|           | MD520-4T5.5B(S)      | 3 x 4                              | TNR3.5-5  | 4                                  | TNR8-5    | M5    |                                     |
| T3        | MD520-4T7.5B(S)      | 3 x 6                              | TNR5.5-5  | 6                                  | TNR5.5-5  | M5    | 2.8<br>(24.8)                       |
|           | MD520-4T11B(S)       | 3 x 10                             | TNR8-5    | 10                                 | TNR8-5    | M5    |                                     |
| T4        | MD520-4T15B(S)       | 3 x 10                             | TNR8-5    | 10                                 | TNR8-5    | M5    | 4.8<br>(45.2)                       |
| T5        | MD520-4T18.5(B)(S)   | 3 x 16                             | GTNR16-6  | 16                                 | GTNR16-6  | M6    |                                     |
|           | MD520-4T18.5(B)(S)-T | 3 x 16                             | GTNR16-6  | 16                                 | GTNR16-6  | M6    |                                     |
|           | MD520-4T22(B)(S)     | 3 x 16                             | GTNR16-6  | 16                                 | GTNR16-6  | M6    |                                     |
|           | MD520-4T22(B)(S)-T   | 3 x 16                             | GTNR16-6  | 16                                 | GTNR16-6  | M6    |                                     |
| T6        | MD520-4T30(B)(S)     | 3 x 25                             | GTNR25-6  | 16                                 | GTNR16-6  | M6    | 4.8<br>(45.2)                       |
|           | MD520-4T37(B)(S)     | 3 x 35                             | GTNR35-6  | 16                                 | GTNR16-6  | M6    |                                     |
| T7        | MD520-4T45(B)(S)     | 3 x 50                             | GTNR50-8  | 25                                 | GTNR25-8  | M8    | 13<br>(115.2)                       |
|           | MD520-4T55(B)(S)     | 3 x 70                             | GTNR70-8  | 35                                 | GTNR35-8  | M8    |                                     |

| Structure | Model               | RST/UWV   |            | Ground Cable  |           | Screw | Tightening Torque<br>N · m<br>(lb.in) |
|-----------|---------------------|---|------------|---|-----------|-------|---------------------------------------|
|           |                     | Cable Size<br>(mm <sup>2</sup> ) <sup>&lt;1&gt;</sup> | Cable Lug  | Cable Size<br>(mm <sup>2</sup> ) <sup>&lt;1&gt;</sup> | Cable Lug |       |                                       |
| T8        | MD520-4T75(B) (S)   | 3 x 95  | GTNR95-12  | 50  | GTNR50-12 | M12   | 35<br>(310.1)                         |
|           | MD520-4T90(S)       | 3 x 120   | GTNR120-12 | 70  | GTNR70-12 | M12   |                                       |
|           | MD520-4T110(S)      | 3 x 150   | GTNR150-12 | 95  | GTNR95-12 | M12   |                                       |
| T9        | MD520-4T132(S)      | 3 x 185   | BC185-12   | 95  | BC95-12   | M12   |                                       |
|           | MD520-4T160(S)      | 2 x (3 x 95)  | BC95-12    | 95  | BC95-12   | M12   |                                       |
| T10       | MD520-4T200(S) (-L) | 2 x (3 x 120)   | BC120-12   | 120   | BC120-12  | M12   |                                       |
|           | MD520-4T220(S) (-L) | 2 x (3 x 150)   | BC150-12   | 150   | BC150-12  | M12   |                                       |
| T11       | MD520-4T250(S) (-L) | 2 x (3 x 185)   | BC185-16   | 185   | BC185-16  | M16   | 85<br>(753.1)                         |
|           | MD520-4T280(S) (-L) | 2 x (3 x 185)   | BC185-16   | 185   | BC185-16  | M16   |                                       |
| T12       | MD520-4T315(S) (-L) | 2 x (3 x 240)   | BC240-16   | 240   | BC240-16  | M16   |                                       |
|           | MD520-4T355(S) (-L) | 2 x (3 x 240)   | BC240-16   | 240   | BC240-16  | M16   |                                       |
|           | MD520-4T400(S) (-L) | 2 x (3 x 300)   | BC300-16   | 300   | BC300-16  | M16   |                                       |

Table 2–2 Cable selection (three-phase 380 V to 480 V) (UL certified)

| Structure | Model                 | RST/UWV                                      |           | Ground Cable                                 |           | Screw |
|-----------|-----------------------|--|-----------|--|-----------|-------|
|           |                       | Cable Size<br>(AWG/mil) <sup>&lt;2&gt;</sup> | Cable Lug | Cable Size<br>(AWG/mil) <sup>&lt;2&gt;</sup> | Cable Lug |       |
| T1        | MD520-4T0.4B(S)       | 14   | TLK2.5-4  | 2 x 14                                       | TLK2.5-4  | M4    |
|           | MD520-4T0.7B(S)       | 14   | TLK2.5-4  | 2 x 14                                       | TLK2.5-4  | M4    |
|           | MD520-4T1.1B(S)       | 14   | TLK2.5-4  | 2 x 14                                       | TLK2.5-4  | M4    |
|           | MD520-4T1.5B(S)       | 14   | TLK2.5-4  | 2 x 14                                       | TLK2.5-4  | M4    |
|           | MD520-4T2.2B(S)       | 14   | TLK2.5-4  | 2 x 14                                       | TLK2.5-4  | M4    |
|           | MD520-4T3.0B(S)       | 14   | TLK2.5-4  | 2 x 14                                       | TLK2.5-4  | M4    |
| T2        | MD520-4T3.7B(S)       | 10   | TLK6-4    | 2 x 10                                       | TLK6-4    | M4    |
|           | MD520-4T5.5B(S)       | 10   | TLK6-5    | 2 x 10                                       | TLK6-5    | M5    |
| T3        | MD520-4T7.5B(S)       | 8  | TLK10-5   | 2 x 8  | TLK10-5   | M5    |
|           | MD520-4T11B(S)        | 6  | TLK16-5   | 6  | TLK16-5   | M5    |
| T4        | MD520-4T15B(S)        | 6  | TLK16-5   | 6  | TLK16-5   | M5    |
| T5        | MD520-4T18.5(B)(S)    | 4  | TLK25-6   | 4  | TLK25-6   | M6    |
|           | MD520-4T18.5(B) (S)-T | 4  | TLK25-6   | 4  | TLK25-6   | M6    |
| T6        | MD520-4T22(B) (S)     | 3  | TLK35-6   | 4  | TLK25-6   | M6    |
|           | MD520-4T22(B) (S)-T   | 2  | TLK35-6   | 4  | TLK25-6   | M6    |
| T7        | MD520-4T30(B) (S)     | 1/0  | TLK50-8   | 3  | TLK35-8   | M8    |
|           | MD520-4T37(B) (S)     | 3/0  | TLK95-10  | 1  | TLK50-8   | M8    |

| Structure | Model               | RST/UWV                                   |             | Ground Cable                              |             | Screw |
|-----------|---------------------|---|-------------|---|-------------|-------|
|           |                     | Cable Size (AWG/mil) <sup>&lt;2&gt;</sup> | Cable Lug   | Cable Size (AWG/mil) <sup>&lt;2&gt;</sup> | Cable Lug   |       |
| T8        | MD520-4T45(B) (S)   | 4/0                                       | TLK120-12   | 1/0                                       | TLK70-12    | M12   |
|           | MD520-4T55(B) (S)   | 300                                       | SQNBS180-12 | 3/0                                       | TLK95-12    | M12   |
|           | MD520-4T75(B) (S)   | 400                                       | SQNBS250-12 | 4/0                                       | TLK120-12   | M12   |
| T9        | MD520-4T90(S)       | 500                                       | SQNBS250-12 | 250                                       | TLK300-12   | M12   |
|           | MD520-4T110(S)      | 2 x 250                                   | SQNBS150-12 | 250                                       | SQNBS150-12 | M12   |
| T10       | MD520-4T132(S)      | 2 x 300                                   | TLK185-12   | 300                                       | TLK185-12   | M12   |
|           | MD520-4T160(S)      | 2 x 350                                   | TLK185-12   | 350                                       | TLK185-12   | M12   |
| T11       | MD520-4T200(S) (-L) | 2 x 350                                   | TLK185-12   | 350                                       | TLK185-12   | M12   |
|           | MD520-4T220(S) (-L) | 2 x 500                                   | SQNBS325-16 | 500                                       | SQNBS325-16 | M16   |
| T12       | MD520-4T250(S) (-L) | 2 x 700                                   | TLK400-16   | 700                                       | TLK400-16   | M16   |
|           | MD520-4T280(S) (-L) | 4 x 300                                   | TLK185-16   | 2 x 300                                   | TLK185-16   | M16   |
|           | MD520-4T400(S) (-L) | 4 x 300                                   | TLK185-16   | 2 x 300                                   | TLK185-16   | M16   |

Table 2-3 Cable selection (three-phase 200 V to 240 V)

| Structure | Model              | RST/UWV  |            | Ground Cable                                       |           | Screw |
|-----------|--------------------|--|------------|--|-----------|-------|
|           |                    | Cable Size (mm <sup>2</sup> ) <sup>&lt;1&gt;</sup> | Cable Lug  | Cable Size (mm <sup>2</sup> ) <sup>&lt;1&gt;</sup> | Cable Lug |       |
| T1        | MD520-2T0.4B(S)    | 3 x 0.75   | TNR0.75-4  | 0.75   | TNR0.75-4 | M4    |
|           | MD520-2T0.7B(S)    |  |            |  |           |       |
|           | MD520-2T1.1B(S)    |  |            |  |           |       |
|           | MD520-2T1.5B(S)    | 3 x 1  | TNR1.25-4  | 1  | TNR1.25-4 |       |
| T2        | MD520-2T2.2B(S)    | 3 x 1.5  | TNR1.25-4  | 1.5  | TNR1.25-4 | M4    |
|           | MD520-2T3.7B(S)    | 3 x 2.5  | TNR2-4     | 2.5  | TNR2-4    | M4    |
| T3        | MD520-2T5.5B(S)    | 3 x 6  | TNR5.5-5   | 6  | TNR5.5-5  | M5    |
| T4        | MD520-2T7.5B(S)    | 3 x 10   | TNR8-5     | 10   | TNR8-5    | M5    |
| T5        | MD520-2T11(B) (S)  | 3 x 16   | GTNR16-6   | 16   | GTNR16-6  | M6    |
| T6        | MD520-2T15(B) (S)  | 3 x 16   | GTNR16-6   | 16   | GTNR16-6  | M6    |
|           | MD520-2T18.5(B)(S) | 3 x 25   | GTNR25-6   | 16   | GTNR16-6  | M6    |
| T7        | MD520-2T22(B)(S)   | 3 x 35   | GTNR35-8   | 16   | GTNR16-8  | M8    |
|           | MD520-2T30(B)(S)   | 3 x 50   | GTNR50-8   | 25   | GTNR25-8  | M8    |
| T8        | MD520-2T37(B) (S)  | 3 x 70   | GTNR70-12  | 35   | GTNR35-12 | M12   |
|           | MD520-2T45(S)      | 3 x 95   | GTNR95-12  | 50   | GTNR50-12 | M12   |
|           | MD520-2T55(S)      | 3 x 120  | GTNR120-12 | 70   | GTNR70-12 | M12   |
| T9        | MD520-2T75(S)      | 2 x (3 x 95)                                       | BC95-12    | 95   | BC95-12   | M12   |

| Structure | Model          | RST/UVW  |           | Ground Cable                                       |           | Screw |
|-----------|----------------|--|-----------|--|-----------|-------|
|           |                | Cable Size (mm <sup>2</sup> ) <sup>&lt;1&gt;</sup> | Cable Lug | Cable Size (mm <sup>2</sup> ) <sup>&lt;1&gt;</sup> | Cable Lug |       |
| T10       | MD520-2T90(S)  | 2 x (3 x 120)                                      | BC120-12  | 120  | BC120-12  | M12   |
|           | MD520-2T110(S) | 2 x (3 x 150)                                      | BC150-12  | 150  | BC150-12  | M12   |
| T11       | MD520-2T132(S) | 2 x (3 x 185)                                      | BC185-16  | 185  | BC185-16  | M16   |
| T12       | MD520-2T160(S) | 2 x (3 x 240)                                      | BC240-16  | 240  | BC240-16  | M16   |
|           | MD520-2T200(S) | 2 x (3 x 240)                                      | BC240-16  | 240  | BC240-16  | M16   |

Table 2-4 Cable selection (single-phase 200 V to 240 V)

| Structure | Model           | RST/UVW  |           | Ground Cable                                       |           | Screw |
|-----------|-----------------|--|-----------|--|-----------|-------|
|           |                 | Cable Size (mm <sup>2</sup> ) <sup>&lt;1&gt;</sup> | Cable Lug | Cable Size (mm <sup>2</sup> ) <sup>&lt;1&gt;</sup> | Cable Lug |       |
| T2        | MD520-2S0.4B(S) | 0.75   | TNR0.75-4 | 0.75   | TNR8-5    | M4    |
|           | MD520-2S0.7B(S) | 1.5  | TNR0.75-4 | 1.5  | TNR8-5    |       |
|           | MD520-2S1.5B(S) | 2.5  | TNR1.25-4 | 1.5  | TNR8-5    |       |
|           | MD520-2S2.2B(S) | 4  | TNR2-4    | 2.5  | TNR8-5    |       |

Table 2-5 Cable selection (single-phase 200 V to 240 V) (UL certified)

| Structure | Model            | RST/UVW          |           | Ground Cable     |           | Screw |
|-----------|------------------|------------------|-----------|------------------|-----------|-------|
|           |                  | Cable Size (AWG) | Cable Lug | Cable Size (AWG) | Cable Lug |       |
| T2        | MD520-2S0.4 B(S) | 14               | TLK2.5-4  | 2 x 14           | TLK2.5-4  | M4    |
|           | MD520-2S0.7 B(S) | 14               | TLK2.5-4  | 2 x 14           | TLK2.5-4  |       |
|           | MD520-2S1.5 B(S) | 14               | TLK2.5-4  | 2 x 14           | TLK2.5-4  |       |
|           | MD520-2S2.2 B(S) | 10               | TLK6-4    | 2 x 10           | TLK6-4    |       |

<1>: Chinese standards applicable; 3 x 10: one 3-core cable; 2 x (3 x 95): two 3-core cables; <2>: American standards applicable; 5: 5AWG; 1/0: 0AWG; 2/0: 00AWG; 3/0: 000AWG; 4/0: 0000AWG; 2 x 250: two 250 kcmil cables.

### Recommended lugs

The following recommended lugs are the TNR, GTNR, and BC series of Suzhou Yuanli. UL-certified lugs are the TLK and SQNBS series of KST.

Table 2-6 Appearance, models, and dimensions of TNR series cable lugs (unit: mm)

| Model     | Cable Size |                 | D   | d1  | E   | F   | B   | d2  | L    | Current (A) | Crimping Tool  |
|-----------|------------|-----------------|-----|-----|-----|-----|-----|-----|------|-------------|----------------|
|           | AWG/MCM    | mm <sup>2</sup> |     |     |     |     |     |     |      |             |                |
|           |            |                 |     |     |     |     |     |     |      |             |                |
| TNR0.75-4 | 22 to 16   | 0.25 to 1.0     | 2.8 | 1.3 | 4.5 | 6.6 | 8.0 | 4.3 | 15.0 | 10          | RYO-8<br>AK-1M |
| TNR1.25-4 | 22 to 16   | 0.25 to 1.65    | 3.4 | 1.7 | 4.5 | 7.3 | 8   | 5.3 | 15.8 | 19          |                |

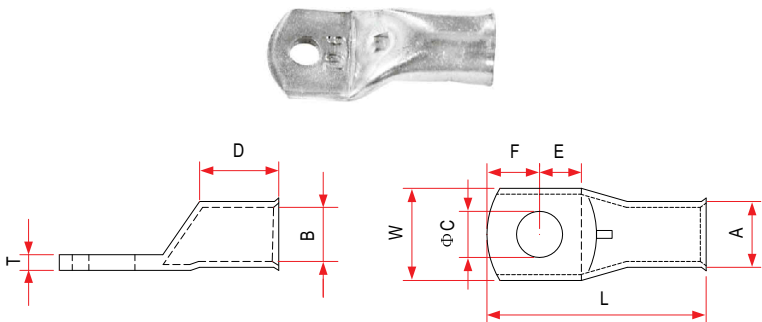

Table 2-7 Appearance, models, and dimensions of GTNR series cable lugs (unit: mm)

| Model     | D    | d1   | E    | H    | K   | B    | d2   | F   | L    | R  | Crimping Tool            |
|-----------|------|------|------|------|-----|------|------|-----|------|----|--------------------------|
|           |      |      |      |      |     |      |      |     |      |    |                          |
| GTNR1.5-5 | 4.0  | 2.2  | 5.0  | 5.0  | 2.0 | 8.0  | 5.3  | 1.0 | 16.0 | 5  | RYO-8<br>YIT-8<br>RYO-14 |
| GTNR2.5-4 | 4.5  | 2.9  | 7.0  | 5.0  | 2.0 | 8.0  | 4.3  | 1.0 | 18.0 | 5  |                          |
| GTNR2.5-5 | 4.5  | 2.9  | 7.0  | 6.0  | 2.0 | 8.0  | 5.3  | 1.0 | 20.0 | 7  |                          |
| GTNR2.5-6 | 4.5  | 2.9  | 7.0  | 6.0  | 2.0 | 10.2 | 6.4  | 0.8 | 20.0 | 7  |                          |
| GTNR4-5   | 5.2  | 3.6  | 7.0  | 6.0  | 2.0 | 10.0 | 5.3  | 1.0 | 20.0 | 7  |                          |
| GTNR4-6   | 5.2  | 3.6  | 7.0  | 6.0  | 2.0 | 10.0 | 6.4  | 1.0 | 20.0 | 7  |                          |
| GTNR6-5   | 6.0  | 4.2  | 9.0  | 6.0  | 3.0 | 10.0 | 5.3  | 1.2 | 23.0 | 7  |                          |
| GTNR6-6   | 6.0  | 4.2  | 9.0  | 7.5  | 3.0 | 10.0 | 6.4  | 1.2 | 26.0 | 7  |                          |
| GTNR6-8   | 6.0  | 4.2  | 9.0  | 7.5  | 3.0 | 12.0 | 8.4  | 1.0 | 26.0 | 7  |                          |
| GTNR10-6  | 7.0  | 5.0  | 9.0  | 8.0  | 3.5 | 12.4 | 6.4  | 1.3 | 26.5 | 7  |                          |
| GTNR10-8  | 7.0  | 5.0  | 9.0  | 8.0  | 3.5 | 12.4 | 8.4  | 1.3 | 27.5 | 7  |                          |
| GTNR16-6  | 7.8  | 5.8  | 12.0 | 8.0  | 4.0 | 12.4 | 6.4  | 1.3 | 31.0 | 7  | CT-38<br>CT-100          |
| GTNR16-8  | 7.8  | 5.8  | 12.0 | 8.0  | 4.0 | 12.4 | 8.4  | 1.3 | 31.0 | 7  |                          |
| GTNR25-6  | 9.5  | 7.5  | 12.0 | 8.0  | 4.5 | 14.0 | 6.4  | 2.0 | 32.0 | 10 |                          |
| GTNR25-8  | 9.5  | 7.5  | 12.0 | 9.0  | 4.5 | 15.5 | 8.4  | 1.6 | 34.0 | 10 |                          |
| GTNR25-10 | 9.5  | 7.5  | 12.0 | 10.5 | 4.5 | 17.5 | 10.5 | 1.4 | 37.0 | 10 |                          |
| GTNR35-6  | 11.4 | 8.6  | 15.0 | 9.0  | 5.0 | 15.5 | 6.4  | 2.8 | 38.0 | 10 |                          |
| GTNR35-8  | 11.4 | 8.6  | 15.0 | 9.0  | 5.0 | 15.5 | 8.4  | 2.8 | 38.0 | 10 |                          |
| GTNR35-10 | 11.4 | 8.6  | 15.0 | 10.5 | 5.0 | 17.5 | 10.5 | 2.5 | 40.5 | 10 |                          |
| GTNR50-8  | 12.6 | 9.6  | 16.0 | 11.0 | 6.0 | 18.0 | 8.4  | 2.8 | 43.5 | 10 | CT-100                   |
| GTNR50-10 | 12.6 | 9.6  | 16.0 | 11.0 | 6.0 | 18.0 | 10.5 | 2.8 | 43.5 | 10 |                          |
| GTNR70-8  | 15.0 | 12.0 | 18.0 | 13.0 | 7.0 | 21.0 | 8.4  | 2.8 | 50.0 | 14 |                          |
| GTNR70-10 | 15.0 | 12.0 | 18.0 | 13.0 | 7.0 | 21.0 | 10.5 | 2.8 | 50.0 | 14 |                          |
| GTNR70-12 | 15.0 | 12.0 | 18.0 | 13.0 | 7.0 | 21.0 | 13.0 | 2.8 | 50.0 | 14 |                          |
| GTNR95-10 | 17.4 | 13.5 | 20.0 | 13.0 | 9.0 | 25.0 | 10.5 | 3.9 | 55.0 | 14 |                          |
| GTNR95-12 | 17.4 | 13.5 | 20.0 | 13.0 | 9.0 | 25.0 | 13.0 | 3.9 | 55.0 | 14 |                          |

| Model      | D    | d1   | E    | H    | K    | B    | d2   | F   | L    | R  | Crimping Tool |
|------------|------|------|------|------|------|------|------|-----|------|----|---------------|
| GTNR120-12 | 19.8 | 15.0 | 22.0 | 14.0 | 10.0 | 28.0 | 13.0 | 4.7 | 60.0 | 16 | RYC-150       |
| GTNR120-16 | 19.8 | 15.0 | 22.0 | 16.0 | 10.0 | 28.0 | 17.0 | 4.7 | 64.0 | 16 |               |
| GTNR150-12 | 21.2 | 16.5 | 26.0 | 16.0 | 11.0 | 30.0 | 13.0 | 4.7 | 69.0 | 24 |               |
| GTNR150-16 | 21.2 | 16.5 | 26.0 | 16.0 | 11.0 | 30.0 | 17.0 | 4.7 | 69.0 | 24 |               |
| GTNR185-16 | 23.5 | 18.5 | 32.0 | 17.0 | 12.0 | 34.0 | 17.0 | 5.0 | 78.0 | 24 |               |
| GTNR240-16 | 26.5 | 21.5 | 38.0 | 20.0 | 14.0 | 38.0 | 17.0 | 5.5 | 92.0 | 24 |               |
| GTNR240-20 | 26.5 | 21.5 | 38.0 | 20.0 | 14.0 | 38.0 | 21.0 | 5.5 | 92.0 | 24 |               |

Table 2-8 Appearance, models, and dimensions of BC series cable lugs (unit: mm)

| Model  | A    | B    | W    | E    | D    | L    | T   | C    | F    |
|--|------|------|------|------|------|------|-----|------|------|
|  |      |      |      |      |      |      |     |      |      |
| 120-8  | 19.0 | 15.0 | 27.2 | 16.5 | 27.0 | 73.0 | 4.0 | 8.5  | 16.5 |
| 120-10   |      |      |      |      |      |      |     | 10.5 |      |
| 120-12   |      |      |      |      |      |      |     | 12.8 |      |
| 120-14   |      |      |      |      |      |      |     | 14.7 |      |
| 120-16   |      |      |      |      |      |      |     | 16.7 |      |
| 120-20   |      |      |      | 20.7 |      |      |     |      |      |
| 150-8  | 21.0 | 16.5 | 30.0 | 18.8 | 27.0 | 78.0 | 4.5 | 8.5  | 16.5 |
| 150-10   |      |      |      | 10.5 |      |      |     |      |      |
| 150-12   |      |      |      | 12.8 |      |      |     |      |      |
| 150-14   |      |      |      | 14.7 |      |      |     |      |      |
| 150-16   |      |      |      | 16.7 |      |      |     |      |      |
| 150-20   |      |      |      | 20.7 |      |      |     |      |      |

| Model  | A    | B    | W    | E    | D    | L    | T   | C    | F    |
|--------|------|------|------|------|------|------|-----|------|------|
| 185-10 | 23   | 18.5 | 33.5 | 16.5 | 30   | 82   | 4.5 | 10.5 | 16.5 |
| 185-12 |      |      |      | 12.8 |      |      |     |      |      |
| 185-14 |      |      |      | 14.7 |      |      |     |      |      |
| 185-16 |      |      |      | 16.7 |      |      |     |      |      |
| 185-20 |      |      |      | 18.8 |      |      |     | 20.7 |      |
| 240-10 | 26   | 21   | 37.7 | 18.0 | 32.0 | 88.0 | 5.0 | 10.5 | 17.0 |
| 240-12 |      |      |      | 12.8 |      |      |     |      |      |
| 240-14 |      |      |      | 14.7 |      |      |     |      |      |
| 240-16 |      |      |      | 16.7 |      |      |     |      |      |
| 240-20 |      |      |      | 20.7 |      |      |     |      |      |
| 300-10 | 28.0 | 23.0 | 41.0 | 18.0 | 37.0 | 97.0 | 5.0 | 10.5 | 17.0 |
| 300-12 |      |      |      | 12.8 |      |      |     |      |      |
| 300-14 |      |      |      | 14.7 |      |      |     |      |      |
| 300-16 |      |      |      | 16.7 |      |      |     |      |      |
| 300-20 |      |      |      | 20.7 |      |      |     |      |      |

## 2.2.2 Selection of Control Circuit Cables

### Note

Connect the control circuit cables according to EN 60204-1.

To prevent peripheral interference and noise, shielded cables are recommended for I/O signal cables. Connect both ends of the shield to the equipment 360 degrees using signal shield support. Separate shielded cables should be used for different analog signals, and shielded twisted pair cables are recommended for digital signal cables.

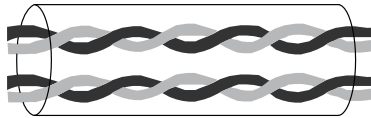

Figure 2-3 Shielded twisted pair cable

### 3 Components

#### 3.1 Overview

The AC drive is structured in either of the following types:

- Plastic structure for T1 to T6 models
- Sheet metal structure for T7 to T12 models

#### 3.2 Components of T1 to T6 Models

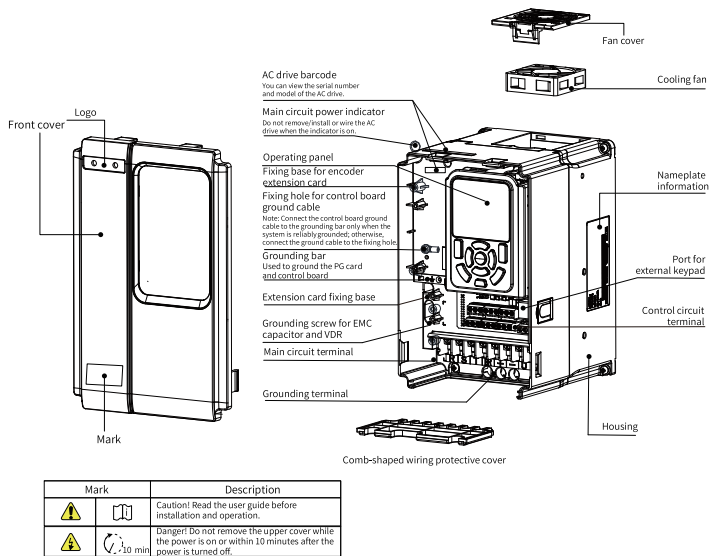

Figure 3-1 Components of T1 to T4 models

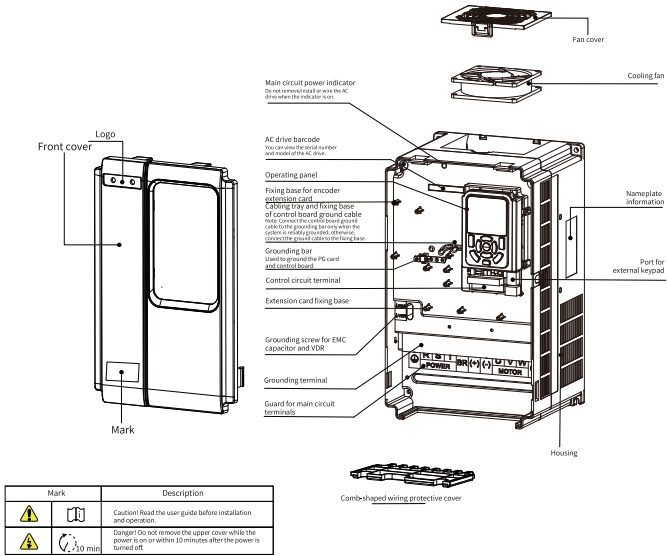
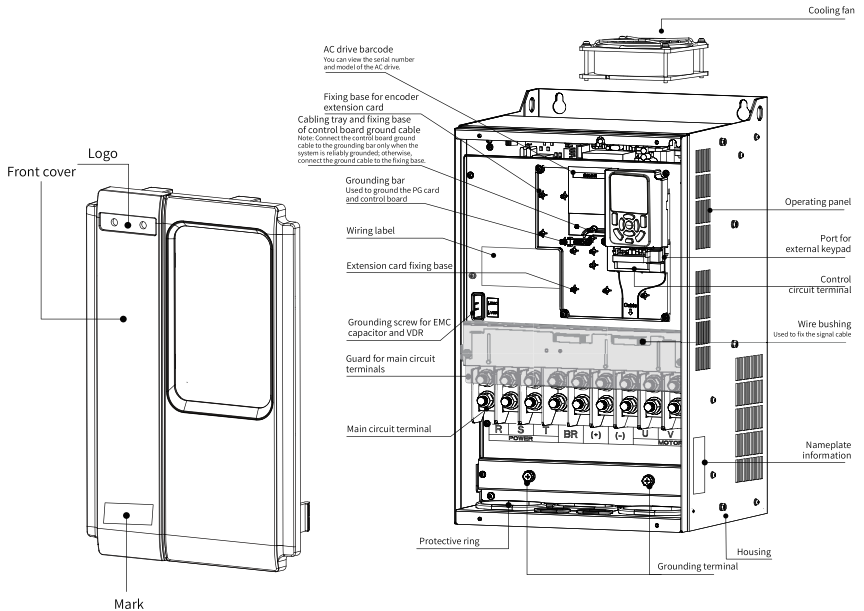

Figure 3-2 Components of T5 and T6 models

### 3.3 Components of T7 to T9 Models







| Mark  | Description   |
|---|---|
|   | Caution! Read the user guide before installation and operation.   |
|   | Danger! Do not remove the upper cover while the power is on or within 10 minutes after the power is turned off. |

Figure 3-3 Components of T7 to T9 models

#### Note

The number and positions of cooling fans vary with AC drive models.

- For T7 models, one cooling fan is provided on the top.
- For T8 models, two cooling fans are provided on the top.
- For T9 models, two cooling fans are provided at the bottom.

### 3.4 Components of T10 to T12 Models

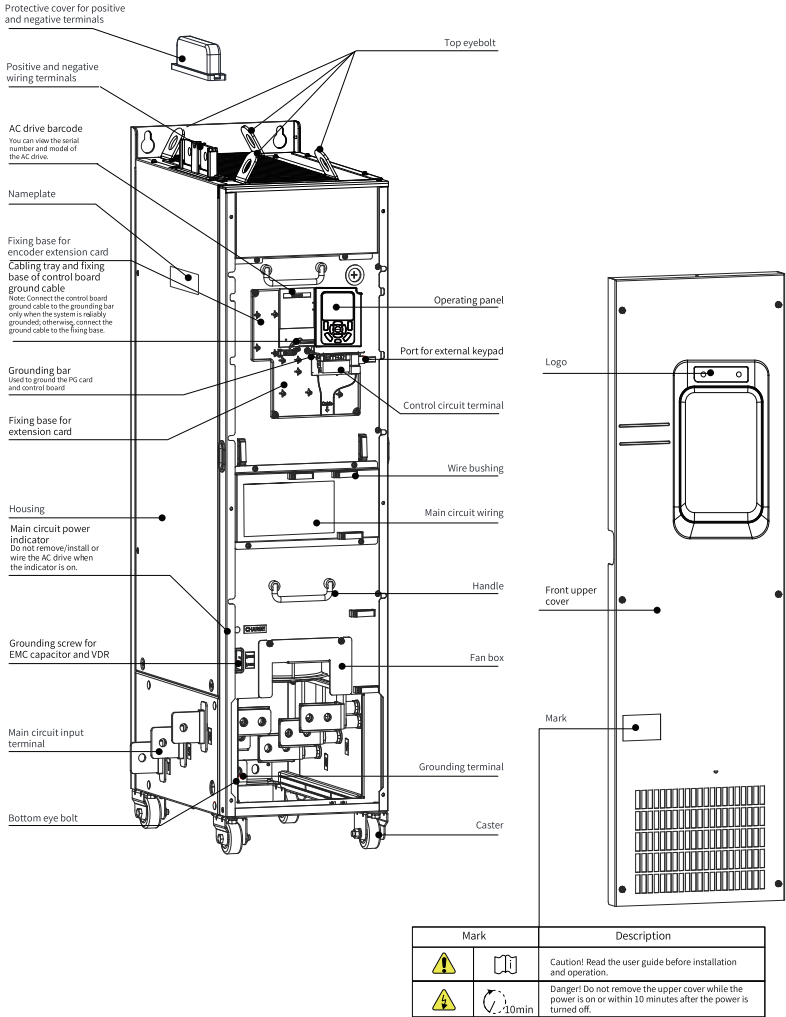

Figure 3-4 Components of T10 to T12 models (without an output AC reactor)

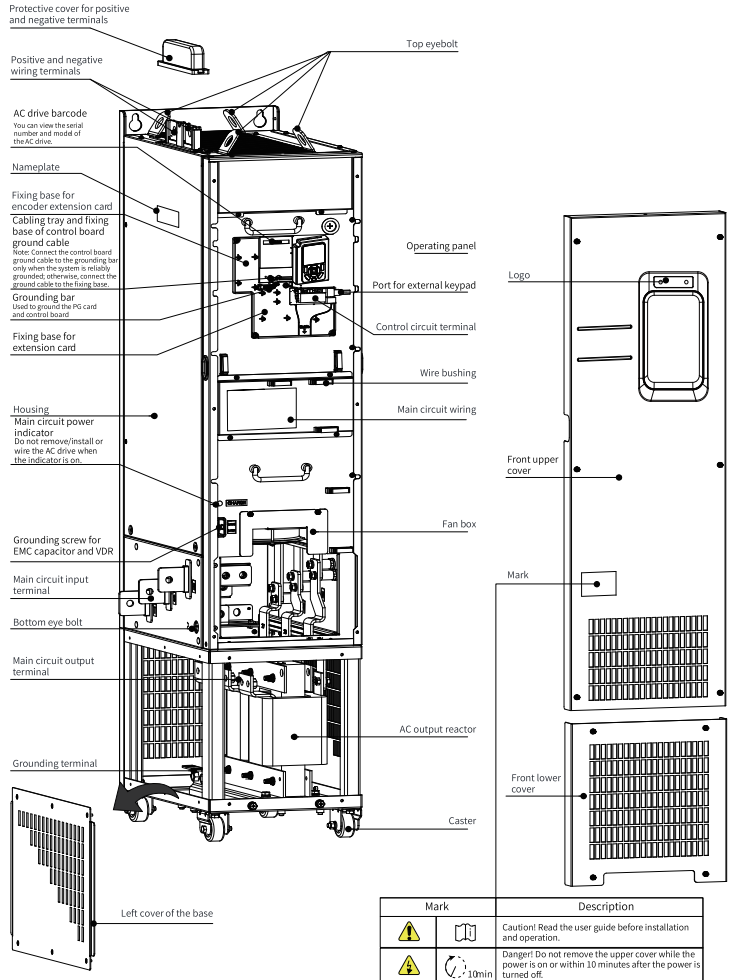

Figure 3-5 Components of T10 to T12 models (with an output AC reactor)



## 4 Operating Panel

### 4.1 LED Operating Panel

#### Dimensions

The following figures show the appearance and installation dimensions of the LED operating panel.

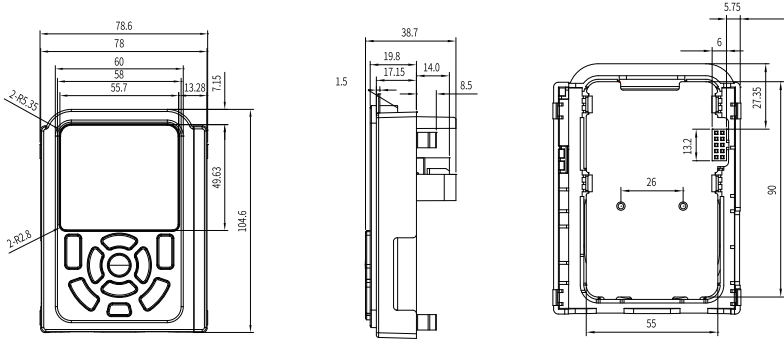

Figure 4-1 Outline dimensions of the LED operating panel for T1 to T4 models (unit: mm)

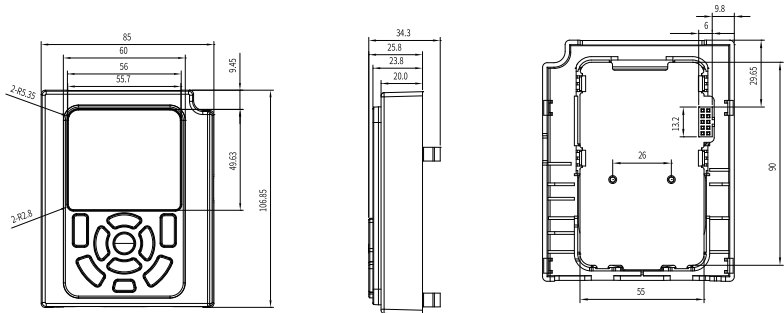

Figure 4-2 Outline dimensions of the LED operating panel for T5 to T12 models (unit: mm)

#### Components

The LED operating panel is used for displaying status and fault information and setting parameters. The following figure shows the operating panel.

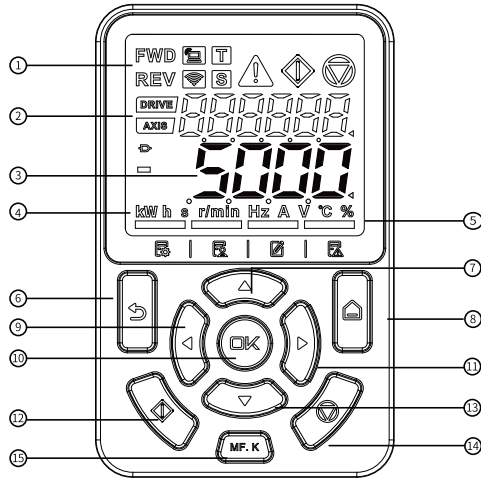

Figure 4-3 Components of the operating panel

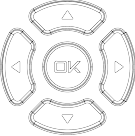



Table 4-1 Components of the operating panel

| No. | Name                   | No. | Name               |
|-----|------------------------|-----|--------------------|
| 1   | Status indicator       | 9   | Left shift key     |
| 2   | Secondary display area | 10  | OK key             |
| 3   | Primary display area   | 11  | Right shift key    |
| 4   | Unit indicator         | 12  | Run key            |
| 5   | Menu indicator         | 13  | Decrement key      |
| 6   | Programming key        | 14  | Stop key           |
| 7   | Increment key          | 15  | Multi-function key |
| 8   | Menu key               | -   | -                  |

**Keys**







Table 4-2 Keys of the operating panel







| Key | Name     | Function   |
|-----|----------|--|
|     | Menu key | Pressing and holding this key toggles between the parameter number display and the multi-function display.<br>Under the multi-function display, pressing this key toggles different menus (including the basic menu, user menu, calibration menu, and fault list). |
|     | Back key | Returns to the previous screen or cancels the setup.   |

| Key   | Name                 | Function   |
|---|----------------------|--|
|  | OK key               | Enters or confirms settings.   |
|  | Navigation key       | <p>Under the multi-function display: Pressing the left/ right shift key toggles the status of display.</p> <p>Under the parameter number display:</p> <ul style="list-style-type: none"> <li>• Basic menu, user menu, and calibration menu: On the monitor page, the down key is used as a keyboard potentiometer, and the left and right keys are used to toggle monitoring variables. On the parameter page, the up and down keys are used to adjust set values, the left and right keys are used to select setting digits, and the OK key is used to confirm the set value.</li> <li>• Fault list: The left and right keys are used to cycle through fault logs.</li> </ul> |
|  | Multi-function key   | Provides function options for the user to choose from, including command source switchover, switchover between forward and reverse run, and jog.   |
|  | Run key              | Starts the AC drive in the operating panel control mode.   |
|  | Stop/Fault reset key | Stops the AC drive when the AC drive is running. Resets the AC drive upon a fault.   |

## Status indicators

Table 4-3 Status indicator description

| Indicator Status  |   | Indication   |
|---|---|--|
|    | FWD indicator steady ON                 | The AC drive is running in the forward direction, or the reference direction is forward. |
|   | REV indicator steady ON                 | The AC drive is running in the reverse direction, or the reference direction is reverse. |
|   | FWD and REV indicators blinking         | The AC drive is switching between forward run and reverse run.                           |
|    | Local/Remote indicator steady OFF       | The AC drive is under local control.   |
|   | Local/Remote indicator steady ON        | The AC drive is under terminal control.  |
|   | Local/Remote indicator slowly blinking  | The AC drive is under communication control.   |
|   | Local/Remote indicator quickly blinking | The AC drive is under custom control.  |
|    | Torque control indicator steady ON      | The AC drive is under torque control.  |
|   | Speed control indicator steady ON       | The AC drive is under speed control.   |
|  | Fault indicator steady ON               | A fault occurs on the AC drive.  |
|   | Fault indicator steady OFF              | No fault occurs on the AC drive.   |
|  | RUN indicator steady ON                 | The AC drive is running.   |
|  | Stop indicator steady ON                | The AC drive has stopped.  |

| Indicator Status  |                                      | Indication  |
|---|--------------------------------------|---|
|    | DRIVE indicator steady ON            | Displayed in the secondary display area is a drive number.              |
|   | DRIVE indicator steady OFF           | Displayed in the secondary display area is not a drive number.          |
|    | AXIS indicator steady ON             | Displayed in the secondary display area is an axis number.              |
|   | AXIS indicator steady OFF            | Displayed in the secondary display area is not an axis number.          |
|    | Connector indicator steady ON        | Displayed in the primary display area is a connector variable.          |
|   | Connector indicator steady OFF       | Displayed in the primary display area is not a connector variable.      |
|    | Minus sign indicator steady ON       | The value displayed in the primary display area is negative.            |
|   | Minus sign indicator steady OFF      | The value displayed in the primary display area is positive.            |
|    | Connector indicator steady ON        | Displayed in the primary display area is a connector variable.          |
|   | Connector indicator steady OFF       | Displayed in the primary display area is not a connector variable.      |
|  | Operating cursor 1 steady ON         | The secondary display area is active.                                   |
|   | Operating cursor 2 steady ON         | The secondary display area is active.                                   |
|  | One of the unit indicators steady ON | The value displayed in the primary display area is the unit that is ON. |

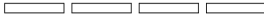
| Indicator Status  |                       | Indication  |
|---|-----------------------|---|
|  | Indicator 1 steady ON | The primary display area displays the basic menu.         |
|   | Indicator 2 steady ON | The primary display area displays the user menu.          |
|   | Indicator 3 steady ON | The primary display area displays the calibration menu.   |
|   | Indicator 4 steady ON | The primary display area displays the fault history menu. |

**Data display**

The operating panel provides two data display areas: the 6-digit LED secondary display area and the 5-digit LED primary display area.

The secondary display area can show the drive number, axis number, current status, and fault/alarm.

The primary display area can show the frequency reference, output frequency, and various monitoring data.

Table 4-4 Mapping between LED display and actual data

| LED Display | Actual Data | LED Display | Actual Data | LED Display | Actual Data | LED Display | Actual Data |
|-------------|-------------|-------------|-------------|-------------|-------------|-------------|-------------|
| 0           | 0           | 9           | 9           | h           | h           | r           | r           |
| 1           | 1           | A           | A           | c           | c           | t           | t           |
| 2           | 2           | b           | B           | J           | J           | U           | U           |
| 3           | 3           | l           | C           | L           | L           | y           | y           |
| 4           | 4           | d           | D           | n           | n           | T           | T           |
| 5           | 5           | E           | E           | N           | N           | u           | u           |

| LED Display | Actual Data | LED Display | Actual Data | LED Display | Actual Data | LED Display | Actual Data |
|-------------|-------------|-------------|-------------|-------------|-------------|-------------|-------------|
| 6           | 6           | F           | F           | o           | o           | -           | -           |
| 7           | 7           | H           | H           | P           | P           | -           | -           |
| 8           | 8           | G           | G           | q           | q           | -           | -           |

## 5 Installation

### 5.1 Personnel

Installation must be carried out by professionals who have received necessary electrical training.

### 5.2 Environment

For optimized performance and a long service life of the AC drive, install the AC drive in an environment that meets the following requirements.

Table 5-1 Environment requirements

| Environment           | Requirement  |
|-----------------------|--|
| Installation location | Indoors  |
| Grid overvoltage      | Overvoltage Class III (OVC III)  |
| Temperature           | <p>Installation/Operation: <math>-10^{\circ}\text{C}</math> to <math>+50^{\circ}\text{C}</math> (<math>-10^{\circ}\text{C}</math> to <math>+40^{\circ}\text{C}</math>: no derating; over <math>+40^{\circ}\text{C}</math>: Derate 1.5% for every additional <math>1^{\circ}\text{C}</math>.)<br/>           Storage/Transportation: <math>-20^{\circ}\text{C}</math> to <math>+60^{\circ}\text{C}</math></p> <ul style="list-style-type: none"> <li>• For better reliability, use the AC drive in places without sharp temperature changes.</li> <li>• For use in an enclosed space such as a control cabinet, use a cooling fan or air conditioner to keep the temperature of air taken into the AC drive below <math>50^{\circ}\text{C}</math>. Failure to comply will result in overheat or fire.</li> <li>• Install the AC drive on a flame-retardant surface, with sufficient clearance reserved for heat dissipation.</li> <li>• Take measures to prevent the AC drive from being frozen.</li> </ul> |
| Humidity              | Below 95% RH, non-condensing   |
| Environment           | <p>Pollution degree: 2 or below<br/>           Install the AC drive in a place that meets the following requirements:</p> <ul style="list-style-type: none"> <li>• Free from direct sunlight, dust, corrosive gas, explosive and inflammable gas, oil mist, vapor, water drop, and salty elements</li> <li>• Insusceptible to vibration (away from equipment that may generate strong vibration, such as a punch press)</li> <li>• Free from unwanted objects such as metal powder, oil, and water that may enter the AC drive</li> <li>• Free from radioactive substances, combustible materials, harmful gas and liquid, and salt corrosion</li> <li>• Away from combustible materials such as wood</li> </ul>   |



| Environment          | Requirement  |
|----------------------|--|
| Altitude             | <ul style="list-style-type: none"> <li>• 1000 m and below: no derating</li> <li>• Above 1000 m: Derate 1% for every additional 100 m.</li> <li>• Above 2000 m for 0.4 kW to 3 kW models: Consult Inovance.</li> <li>• Above 3000 m for 3 kW and above models: Consult Inovance.</li> </ul> |
| Vibration resistance | <ul style="list-style-type: none"> <li>• Transportation with packages: compliant with Class 2M3 requirements in EN 60721-3-2</li> <li>• Installation without packages: compliant with ISTA 1H</li> </ul>   |

### 5.3 Clearance

Reserve sufficient clearance as appropriate to the power rating of the AC drive.

#### T1 to T9 models

- Installing one alone

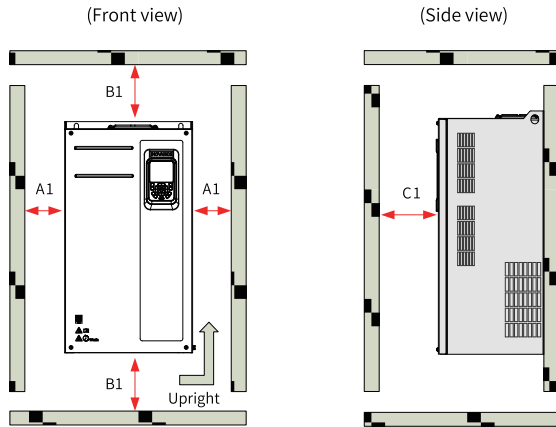

Figure 5-1 Clearance for installation of one AC drive (T1 to T9 models)

Table 5-2 Installation clearance

| Power Rating     | Clearance (mm) |               |              |
|------------------|----------------|---------------|--------------|
| 0.4 kW to 15 kW  | $A1 \geq 10$   | $B1 \geq 100$ | $C1 \geq 40$ |
| 18.5 kW to 22 kW | $A1 \geq 10$   | $B1 \geq 200$ | $C1 \geq 40$ |
| 30 kW to 37 kW   | $A1 \geq 50$   | $B1 \geq 200$ | $C1 \geq 40$ |
| 45 kW to 160 kW  | $A1 \geq 50$   | $B1 \geq 300$ | $C1 \geq 40$ |

- Installing side by side  
 The AC drive dissipates heat upward. When multiple AC drives are required to work together, install them side by side. Keep their tops level with each other, especially for those of different sizes.

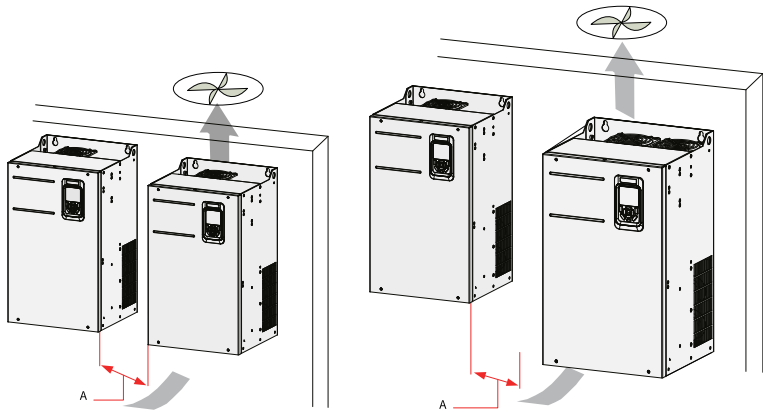

Figure 5-2 Installing multiple AC drives (T1 to T9 models) side by side

Table 5-3 Installation clearance

| Power Rating     | Clearance (mm) |
|------------------|----------------|
| 0.4 kW to 15 kW  | $A1 \geq 10$   |
| 18.5 kW to 22 kW | $A1 \geq 10$   |
| 30 kW to 37 kW   | $A1 \geq 50$   |
| 45 kW to 160 kW  | $A1 \geq 50$   |

- Installing one above another  
Where an AC drive needs to be installed above another, the heat generated by the lower AC drive may act on the upper one, causing over-temperature or overload of the upper one. In this case, install an air guide plate, as shown in ["Figure 5-3 Installing one above another"](#) on page 42.

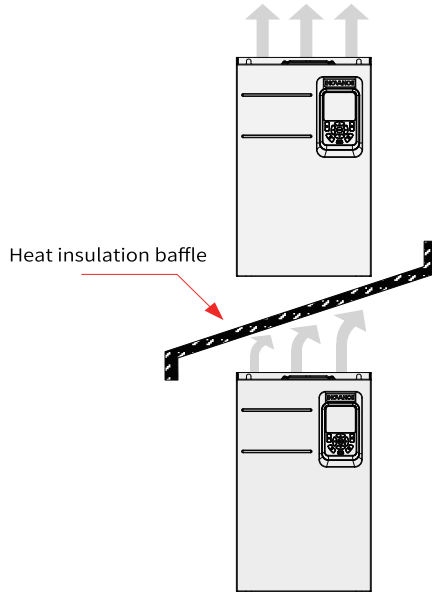

Figure 5-3 Installing one above another

### T10 to T12 models

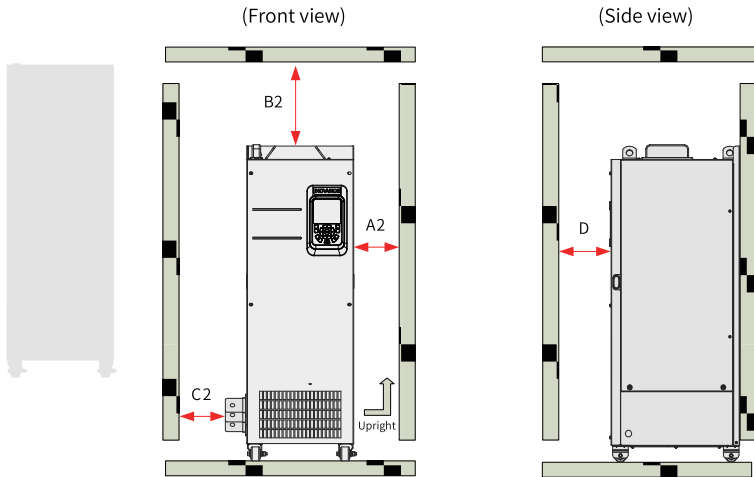

Figure 5-4 Installation clearance

Table 5–4 Installation clearance

| Power Rating     | Clearance (mm) |               |              |              |
|------------------|----------------|---------------|--------------|--------------|
| 200 kW to 400 kW | A2 $\geq$ 10   | B2 $\geq$ 250 | C2 $\geq$ 20 | D2 $\geq$ 20 |

## Note

T10 to T12 models can only be installed in cabinets individually. They cannot be installed in a side-by-side or up-down way. If side-by-side or up-down installation is required, contact Inovance.

## 5.4 Tools

### Tools for mechanical installation

Table 5–5 Tools for mechanical installation (T1 to T12 models)

| Tool  | Description   |
|---|---|
| Electric drill with an appropriate drilling bit     | Used to drill mounting holes on the mounting surface  |
| Wrench or socket wrench                             | Used to tighten or loosen screws<br>Wrench sizes: 13, 16, and 18  |
| Phillips and straight screwdrivers (2.5 mm to 6 mm) | Used to tighten or loosen screws  |
| Torque wrench                                       | Used to tighten or loosen screws  |
| Crowbar   | Used to pry off the upper access cover or cover to facilitate installation                                  |
| Crane   | Used to lift the AC drive   |
| Tape measure  | Used to measure the installation dimensions of the AC drive   |
| Gloves  | Used to prevent static electricity during mechanical installation   |
| Bottom mounting bracket (standard)                  | Used to fix the AC drive in the cabinet   |
| Guide rails (optional)                              | Connected to the bottom mounting bracket to gently push the AC drive into the cabinet along the guide rails |
| Screws  | Used to fix the AC drive onto the mounting surface  |

## Screws

Table 5–6 Specifications and quantities of screws (T1 to T9 models)

| Installation Method   | Specification  | Quantity (PCS) | Description  |
|-----------------------|--|----------------|--|
| Backplate mounting    | Dependent on the mounting hole diameter (provided by the user) | 4              | Used to fix the AC drive onto the wall                             |
| Through-hole mounting | Dependent on the mounting hole diameter (provided by the user) | 4              | Used to fix the AC drive onto the backplate of the control cabinet |

Table 5–7 Specifications and quantities of screws (T10 to T12 models)

| Installation Method       | Specification         | Quantity (PCS) | Description  |
|---------------------------|-----------------------|----------------|--|
| Installation in a cabinet | M5 self-tapping screw | 6              | Used to fix the bottom mounting bracket to the bottom of the cabinet   |
|                           | M5x12 SEMS screw      | 8              | Used to assemble the guide rails                                       |
|                           | M6 nut                | 2              | Used to connect the guide rail assembly to the bottom mounting bracket |

## Tools for wiring

For wiring of main circuit terminals, use installation tools appropriate to terminal dimensions and secure the joints well.

Table 5–8 Wiring tools for main circuit terminals

| Model     | Recommended Fastener                    | Tool  |
|-----------|---|---|
| T1 and T2 | M4 SEMS screw                           | Phillips screwdriver (#3 slot)                                      |
| T3 and T4 | M5 SEMS screw                           | Phillips screwdriver (#3 slot)                                      |
| T5 and T6 | M6 SEMS screw                           | Phillips screwdriver (#3 slot)                                      |
| T7        | M8 nut, spring washer, and flat washer  | Socket wrench (#13 socket)  |
| T8 and T9 | M12 nut, spring washer, and flat washer | Socket wrench (#19 socket) and socket wrench extension bar (150 mm) |

| Model       | Recommended Fastener                     | Tool  |
|-------------|--|---|
| T10 and T11 | M12 bolt, spring washer, and flat washer | Socket wrench (#19 socket) and socket wrench extension bar (250 mm) |
| T12         | M16 bolt, spring washer, and flat washer | Socket wrench (#24 socket) and socket wrench extension bar (250 mm) |

## 5.5 Unpacking and Transportation

### 5.5.1 Package Check

Upon receiving the AC drive from the transport company, check the items received against the delivery note. Notify the transport company immediately in the case of any missing or damaged items. If necessary, request support from Inovance or your local agent.

Packing method and components vary with models due to difference in structural dimensions and weight.



The electrical safety performance of the AC drive may be affected if it is damaged during transportation. Avoid connecting the AC drive without a professional high-voltage test on it.

---

### Packing list for T1 to T9 models

- T1 to T6 models are packed using cartons.
- T7 to T9 models are packed using cartons and plywood pallets.

The following packing components are used:

- Packing list for T1 to T6 models

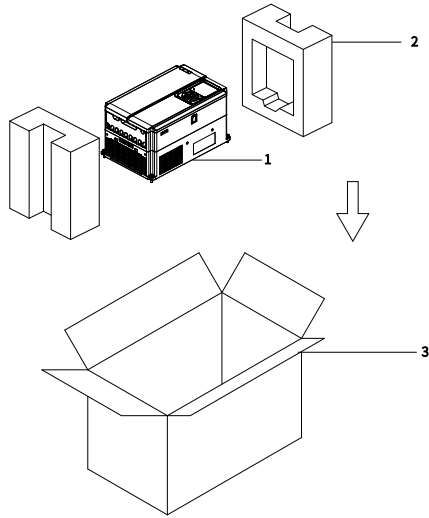

Figure 5-5 Packing list for T1 to T6 models

| No. | Name     |
|-----|----------|
| 1   | AC drive |
| 2   | Cushion  |
| 3   | Carton   |

- Packing list for T7 to T9 models

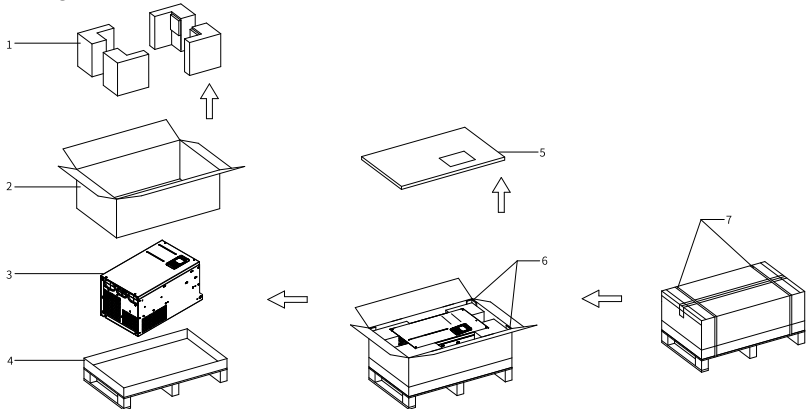

Figure 5-6 Packing list for T7 to T9 models

| No. | Name    |
|-----|---------|
| 1   | Cushion |
| 2   | Carton  |

| No. | Name                   |
|-----|------------------------|
| 3   | AC drive               |
| 4   | Plywood pallet         |
| 5   | Honeycomb cardboard    |
| 6   | Paper corner protector |
| 7   | Tie                    |

### Packing list for T10 to T12 models

- T10 to T11 models are packed using cartons and plywood pallets.
- T12 models are packed using wooden crates.

The following packing components are used:

- Packing list for T10 model

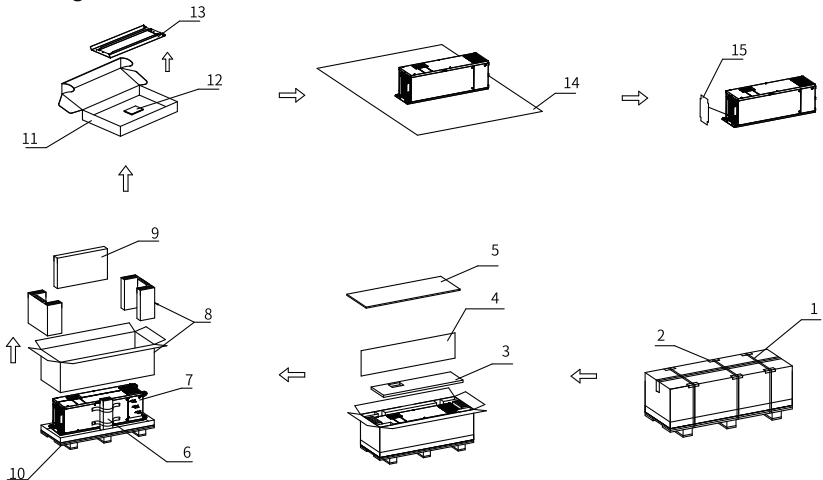

Figure 5-7 Packing list for T10 model

| No. | Name                   |
|-----|------------------------|
| 1   | Packing belt           |
| 2   | Paper corner protector |
| 3   | Honeycomb cardboard    |
| 4   | Corrugated cardboard   |
| 5   | 9 mm board             |
| 6   | Paper column           |
| 7   | AC drive               |



| No. | Name                 |
|-----|----------------------|
| 8   | Carton               |
| 9   | Bracket box          |
| 10  | Wooden pallet        |
| 11  | Carton               |
| 12  | User guide           |
| 13  | Bracket              |
| 14  | Plastic bag          |
| 15  | Corrugated cardboard |

- Packing list for T11 model

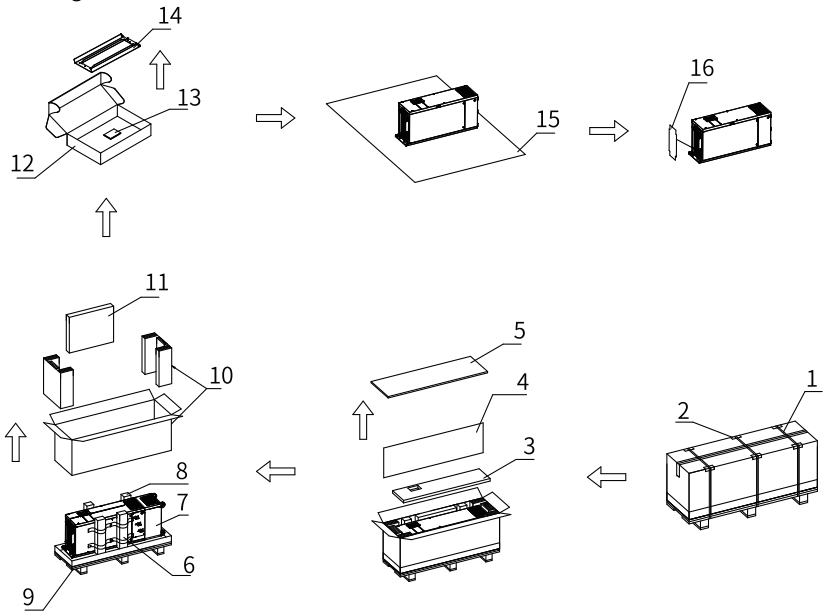

Figure 5-8 Packing list for T11 model

| No. | Name                   |
|-----|------------------------|
| 1   | Packing belt           |
| 2   | Paper corner protector |
| 3   | Honeycomb cardboard    |
| 4   | Corrugated cardboard   |
| 5   | 9 mm board             |

| No. | Name                 |
|-----|----------------------|
| 6   | Paper column         |
| 7   | AC drive             |
| 8   | Paper column         |
| 9   | Wooden pallet        |
| 10  | Carton               |
| 11  | Bracket box          |
| 12  | Carton               |
| 13  | User guide           |
| 14  | Bracket              |
| 15  | Plastic bag          |
| 16  | Corrugated cardboard |

- Packing list for T12 model

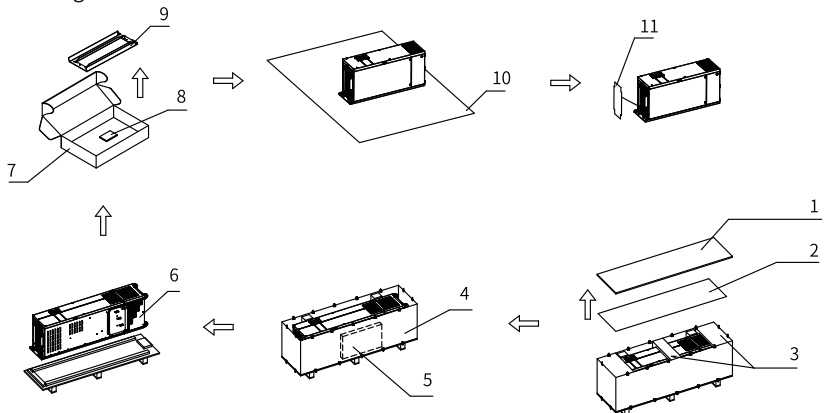

Figure 5-9 Packing list for T12 model

| No. | Name                  |
|-----|-----------------------|
| 1   | Cover                 |
| 2   | Corrugated cardboard  |
| 3   | Expanded polyethylene |
| 4   | Wooden crate          |
| 5   | Bracket box           |
| 6   | AC drive              |
| 7   | Carton                |
| 8   | User guide            |

| No. | Name                 |
|-----|----------------------|
| 9   | Bracket              |
| 10  | Plastic bag          |
| 11  | Corrugated cardboard |

## 5.5.2 Transportation Before Unpacking

### T1 to T12 models

Precautions for transporting T1 to T12 models:

- T1 to T6 models are relatively small and light and therefore can be handled manually. T7 to T12 models, however, must be transported with an appropriate lifting tool.
- Fasten the AC drive onto a wooden pallet for transport on a forklift. Fasten the AC drive onto a pallet before hoisting it, as shown in the following figure.

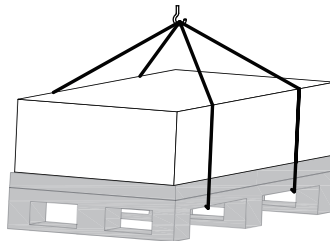
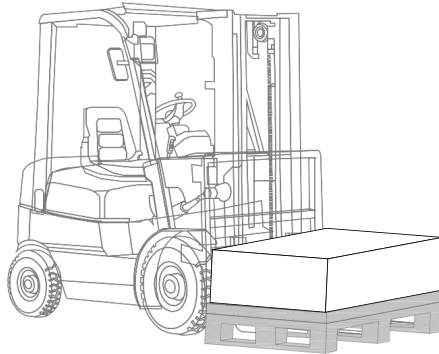

Figure 5-10 Hoisting the AC drive

- T9 to T12 models are heavy with a high center of gravity. Therefore, avoid placing them on any surface inclining greater than 5 degrees. Place the AC drive on a flat and sturdy floor capable of bearing the weight of the AC drive.

- During transportation, keep the AC drive upright as indicated on the packaging box, as shown in the following figure.

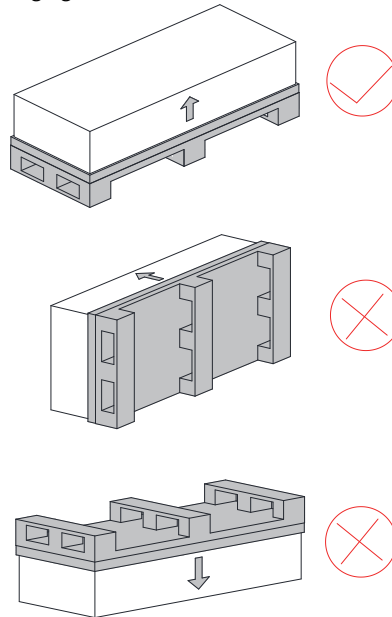

Figure 5-11 Placing the AC drive

### 5.5.3 Transportation and Hoisting After Unpacking

T1 to T6 models are relatively small and light and therefore can be handled manually. T7 to T12 models, however, must be transported with an appropriate hoisting tool.

| Weight of AC Drive | Persons Needed for Transporting          |
|--------------------|--|
| < 15 kg            | 1  |
| $\geq$ 15 kg       | > 2; with an appropriate hoisting device |

Precautions for transporting and hoisting:

- Comply with local regulations.
- Avoid handling the AC drive by directly holding its upper access cover or enclosure. Before moving it, check that all screws are tightened. Failure to comply may result in fall-off of the AC drive, causing injury.
- For T10 to T12 models, ensure that the four mounting holes on the back of the AC drive are connected to the fixing beams.
- Erect the AC drive that is lying flat before hoisting or moving it.
- Where applicable, use a crane with a capacity greater than the weight of the AC drive.

- Before vertical hoisting, make sure that all components of the AC drive, including the upper access cover and terminals, are fastened with screws. Failure to comply may result in fall-off of the AC drive, causing injury.
- When hoisting the AC drive with a sling, protect the AC drive from excessive vibration or impact. Failure to comply may result in fall-off of the AC drive, causing injury.
- When hoisting the AC drive with a sling, do not overturn the AC drive or leave it suspended for a long time. Failure to comply may result in fall-off of the AC drive, causing injury.

### T1 to T9 models

To hoist T1 to T9 models, follow these steps:

1. Hook the sling to the two auxiliary eye bolts at the top of the AC drive.  
Keep the hoisting angle greater than 45 degrees and the fluctuation within 0.3 m.

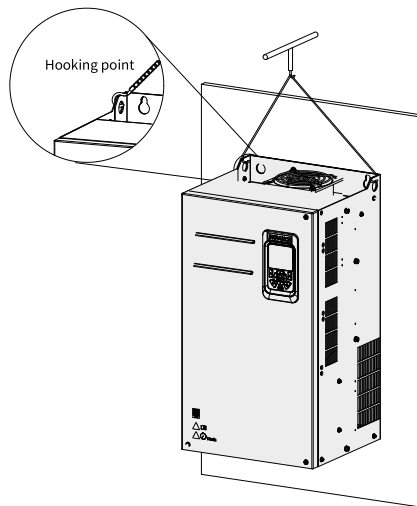

Figure 5-12 Hoisting T1 to T9 models

2. Gradually tension the sling with the crane, and then hoist the AC drive.
3. Slowly lower the AC drive to an appropriate height and suspend it until it is stable.  
Then, gently place the AC drive on the floor or mounting surface for installation in the control cabinet.

### T10 to T12 models

To hoist T10 to T12 models, follow these steps:

1. Hook the hoisting lug and eye bolt at the top and bottom of the AC drive, take out the AC drive from the packing box, and lay it flat on the floor.

Ensure that there is no stress on the positive and negative bus terminals.

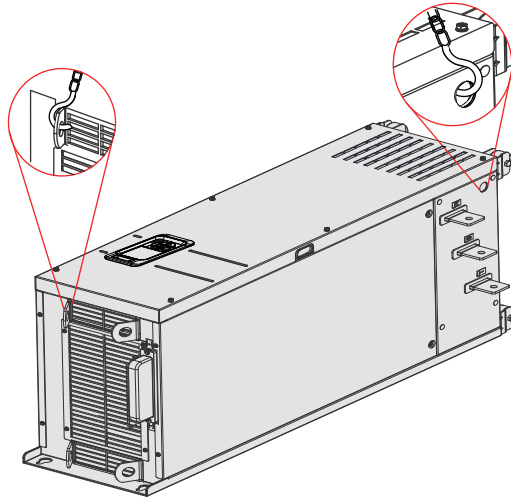

Figure 5-13 Hoisting T10 to T12 models

2. Hook the sling to the hoisting lugs diagonally placed at the top of the AC drive, slowly put the AC drive upright for installation in the cabinet.



Avoid stress on any side of the AC drive or placing it on an inclined surface. The AC drive is large and heavy (close to 200 kg). If the inclination exceeds 5°, it may topple.

## 5.5.4 Unpacking

### T1 to T12 models

Related documents and accessories are placed in different partitions in the crate. To unpack, follow these steps:



1. Remove all ties and the cover of the crate.
2. Remove all packing materials.
3. Take out the AC drive.
4. Cut and remove the plastic wrap around the AC drive.
5. Check for damage.
6. Dispose of or recycle the packaging in accordance with local regulations.

### 5.5.5 Storage

- Store the AC drive in a clean and dry space, with an ambient temperature ranging from  $-20^{\circ}\text{C}$  to  $+60^{\circ}\text{C}$  and a temperature change rate less than  $1^{\circ}\text{C}/\text{min}$ .
- For long time storage, cover the AC drive or take other appropriate measures to keep it from contamination and environmental influences.
- For storage, pack the AC drive with the original packing box provided by Inovance.
- Avoid exposing the AC drive to moisture, high temperature, or outdoor direct sunlight for an extended period.
- To avoid degradation of electrolytic capacitor during long-term storage, energize the AC drive once every six months, each time lasting at least 5 hours. Use a regulator to increase the input voltage gradually to the rated value. For any doubt, contact Inovance.

### 5.6 Cable Preparation

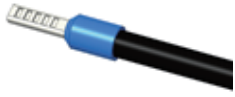
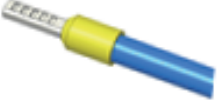
Table 5-9 Cables

| Cable Type         | Cable Name   | Diagram   | Cable Type            | Cable Name    | Diagram   |
|--------------------|--------------|---|-----------------------|---------------|---|
| Main circuit cable | Power cable  |    | Control circuit cable | Signal cable  |   |
|                    | Ground cable |  |                       | Network cable |  |

### 5.7 Mechanical Installation

#### 5.7.1 Installation Methods

The MD520 series AC drives support different installation methods depending on the model.

- T1 to T9 models support backplate mounting and through-hole mounting.
- T10 to T12 models can be installed in a cabinet.

## 5.7.2 Inspection Before Installation

Complete the following inspection items before installation.

Table 5-10 Pre-installation inspection checklist

| No. | Item   |
|-----|--|
| 1   | The installation position is mechanically strong enough to bear the weight of the AC drive.  |
| 2   | The load-bearing capacity of the ground and the environment meet the installation requirements.  |
| 3   | Sufficient clearance is reserved for heat dissipation, including heat dissipation of other devices in the cabinet.   |
| 4   | The mounting bracket (if needed) is made of flame-retardant material.  |
| 5   | If the application site is exposed to metal powder, install the AC drive in a completely enclosed cabinet that has enough space to isolate the AC drive from metal powder.   |
| 6   | Before installing the AC drive, install the bottom mounting bracket and guide rails in the cabinet, and prepare fixing beams with fixing holes for retaining the AC drive. Reserve sufficient clearance in the cabinet for connecting side copper busbars. |
| 7   | Keep combustible and explosive materials away from the AC drive.   |

## 5.7.3 Installing the AC Drive

### 5.7.3.1 Backplate Mounting

For backplate mounting, fasten all retaining nuts, instead of only the two retaining nuts on the top of the AC drive. Otherwise, the connections will come loose or damaged with time due to uneven distribution of loads.



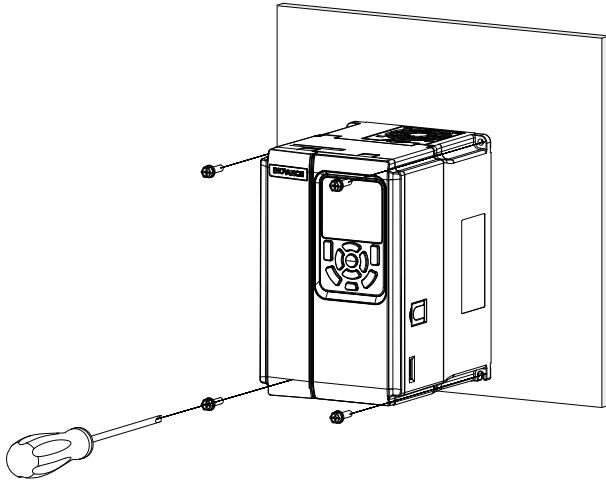

Figure 5-14 Backplate mounting (T1 to T6 models)

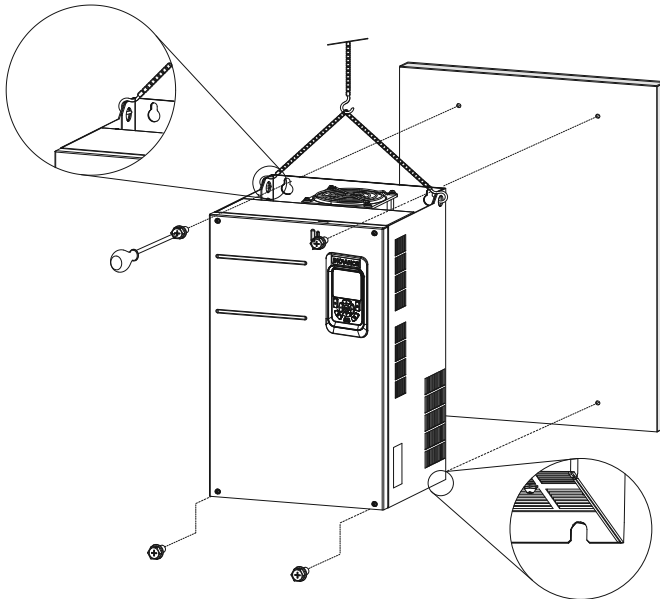
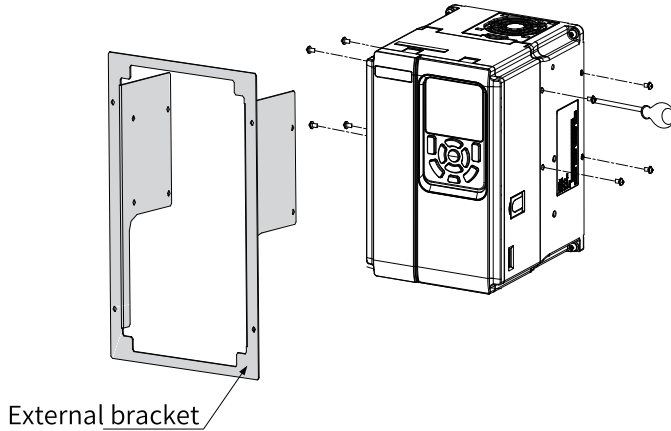

Figure 5-15 Backplate mounting (T7 to T9 models)

### 5.7.3.2 Through-Hole Mounting

#### T1 to T6 models

1. Frame the AC drive with the bracket and tighten the bracket fixing screws on both sides of the AC drive.



The following figure shows an AC drive with a bracket mounted.

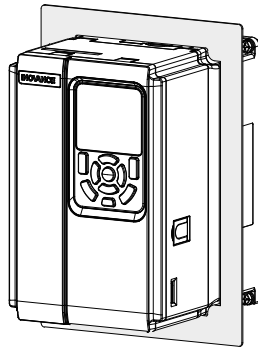

2. Fasten the AC drive with the bracket onto the mounting backplate of the control cabinet.

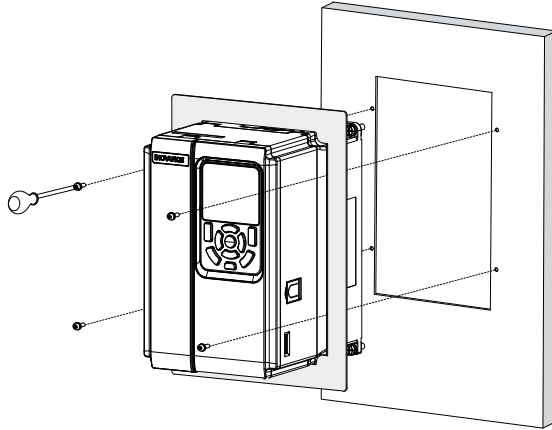

The following figure shows an AC drive that is through-hole mounted.

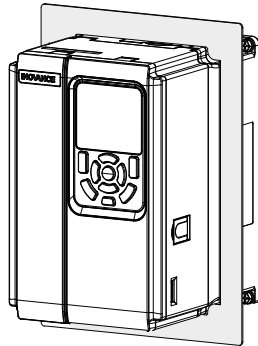

### T7 to T9 models

1. Fasten brackets from the two sides of the AC drive.

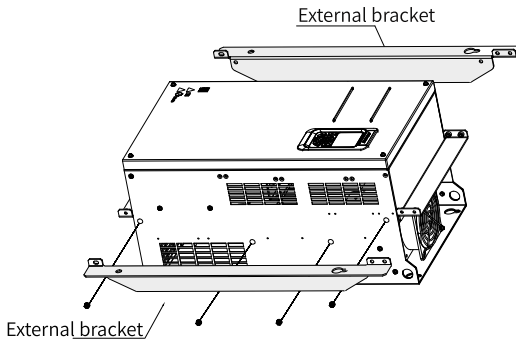

The following figure shows an AC drive with brackets mounted.

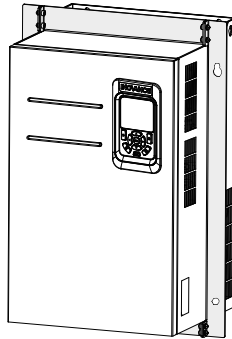

2. Fasten the AC drive onto the backplate of the control cabinet from the front of the control cabinet.

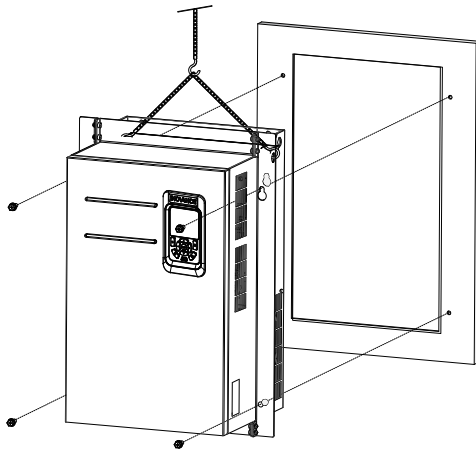

The following figure shows an AC drive that is through-hole mounted.

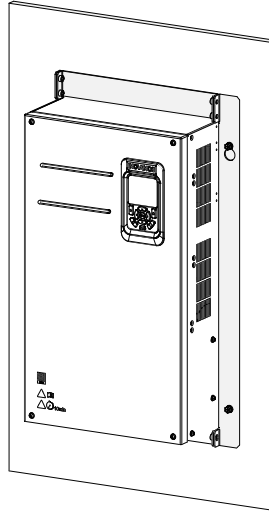

### 5.7.3.3 Installation in a Cabinet

#### Context

Use a nine-fold profile cabinet (PS cabinet) to contain the AC drive. Nine-fold profile cabinets employ assembled frames and therefore save the cost. Columns of the cabinets come with openings conforming to common standards and therefore simplify installation of fixing beams and reinforcements, making the cabinets versatile. Nine-fold profile cabinets are more reliable than standard cabinets. They are considered as the benchmark of the industry. *"Figure 5-16 " on page 61* shows the cross section of the nine-fold profile.

#### Procedure

1. Install the fixing beams in the nine-fold profile cabinet (PS cabinet) and reserve mounting holes for fastening the AC drive.

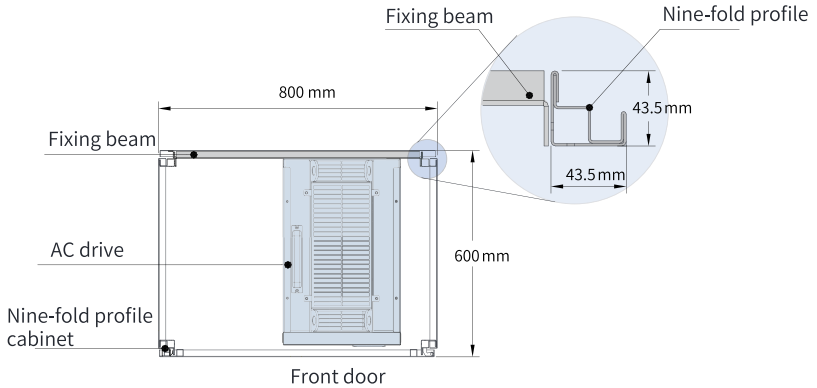

Figure 5-16 Top view of a cabinet for T11 and T12 models

To install a T11 or T12 model in a nine-fold profile cabinet 600 mm in depth, fold the back mounting plate inward, as shown in ["Figure 5-17" on page 61](#), to borrow the space of the column. (This requirement is not applicable to standard cabinets greater than 800 mm in depth.) To install a T11 or T12 model in a cabinet with access doors at both the front and the back, use a cabinet that is 800 mm in depth, instead of a 600 mm one.

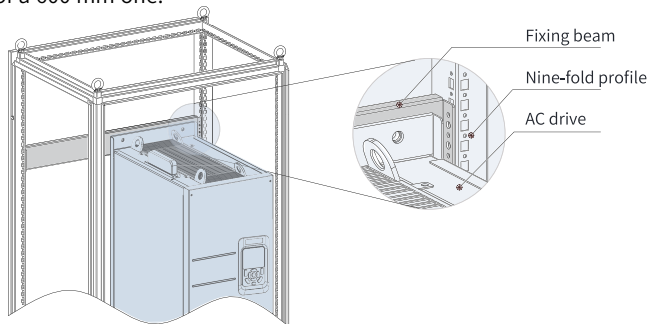

Figure 5-17 Perspective view of a cabinet for T11 and T12 models

2. Fix the bottom mounting bracket in the nine-fold profile cabinet. Use six M5 self-tapping screws to fix the mounting bracket onto the rack base of the nine-fold profile cabinet, as shown in ["Figure 5-18" on page 62](#).

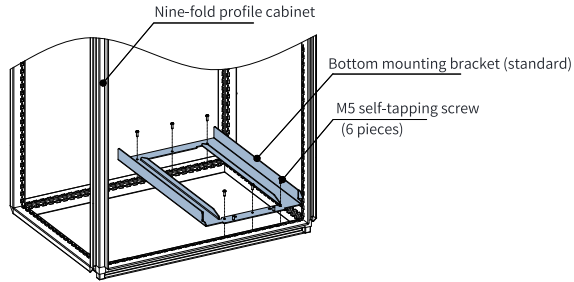

Figure 5-18 Installing the bottom mounting bracket

Drill holes for the mounting bracket and assemble the bracket on site if the cabinet is not a nine-fold profile one.

3. Assemble the guide rails (model: MD500-AZJ-A3T10) and mount them on the cabinet.

a. Assemble the guide rails, as shown in "Figure 5-19 " on page 62 .

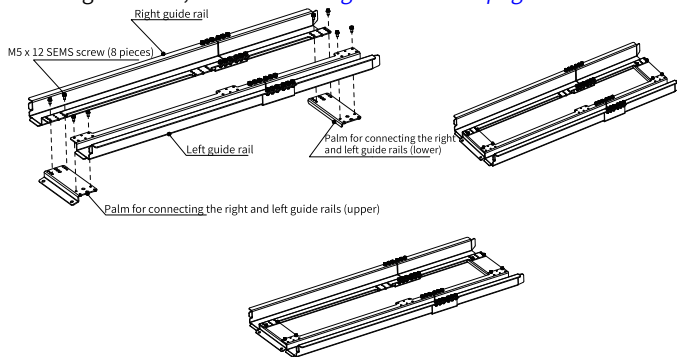

Figure 5-19 Assembling guide rails

b. Align the two round holes on the front end of the guide rails with the screws of the mounting bracket, and lock them with two M6 nuts, to mount the guide rails on the cabinet, as shown in "Figure 5-20 " on page 63 .

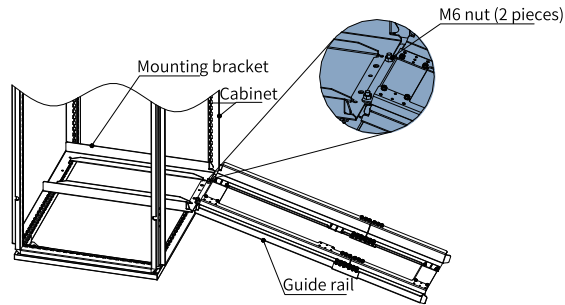

Figure 5-20 Mounting the guide rails on the cabinet

4. Remove the cover from the AC drive.  
For details about how to remove the cover, see "Removing the Cover". Remove the cover to access the auxiliary handle on the AC drive.
5. Align the casters of the AC drive with the guide rails and gently push the AC drive in to the cabinet.  
When pushing or pulling the AC drive, use an auxiliary strap to prevent it from toppling. It is recommended that two persons cooperate to complete this job.

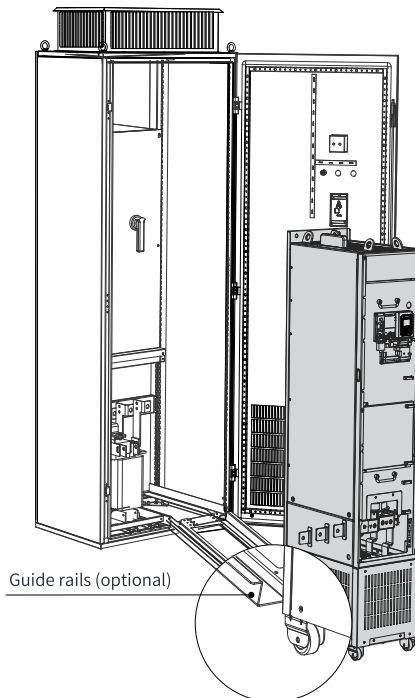

Figure 5-21 Aligning the casters with the guide rails



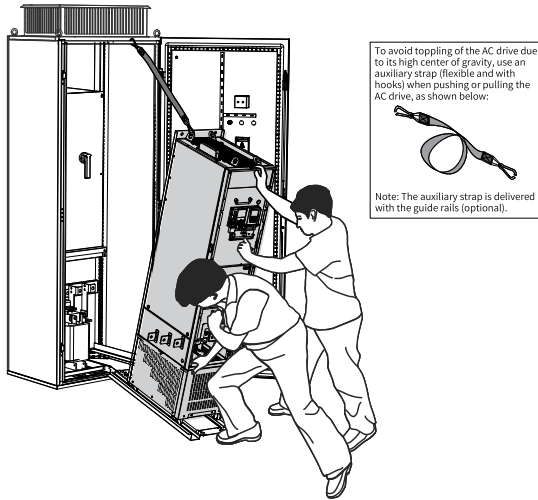

Figure 5-22 Pushing the AC drive into the cabinet

6. Remove the auxiliary strap, and drive screws into the four mounting holes on the back of the AC drive to fasten the AC drive to the fixing beams in the cabinet.

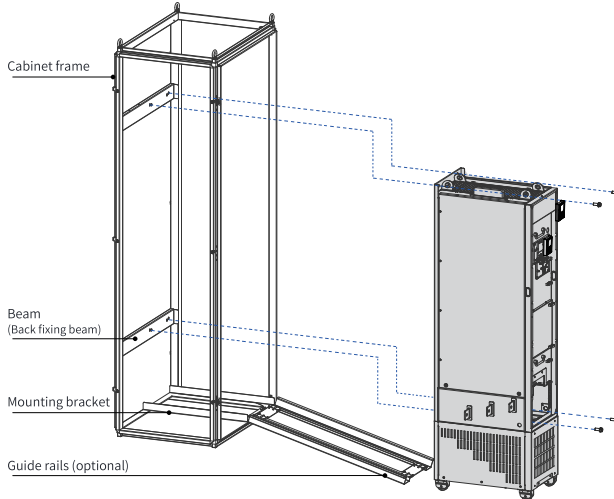

Figure 5-23 Fastening the AC drive to the fixing beams

7. Verify that the AC drive is securely installed, and remove the guide rails.
8. Remove the baffle from the top air filter of the AC drive. The baffle is used to prevent foreign objects, such as screws, from falling into the air filter during installation of the AC drive.

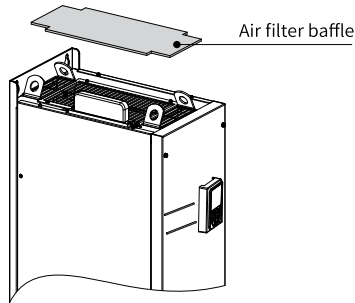

Figure 5-24 Removing the air filter baffle

## 5.7.4 Inspection After Installation

After the installation is completed, inspect the items in the following table and tick compliant items.

Table 5–11 Post-installation inspection checklist

| No. | Item   | Compliance |
|-----|--|------------|
| 1   | The anti-tilt label is contact.  |            |
| 2   | The ceiling height meets the minimum requirements (for smooth ventilation). The air inlet and air outlet are clear of obstruction and have sufficient space. Sufficient space is reserved for safe passing with the cabinet door open. |            |
| 3   | The wooden pallets for transportation are removed after the AC drive is delivered to the installation location.  |            |
| 4   | The cabinet is firmly attached to the fixing points provided.  |            |
| 5   | All contact protection devices (such as the guard) inside and outside the cabinet are installed.   |            |

## 5.8 Electrical Installation

### 5.8.1 Inspection Before Wiring

Complete the following inspection items before wiring.

Table 5–12 Pre-wiring inspection checklist

| No. | Item  |
|-----|---|
| 1   | The diameter and shield of the cables used meet corresponding requirements. |
| 2   | The AC drive is properly grounded.  |

| No. | Item  |
|-----|---|
| 3   | Follow the proper electrostatic discharge (ESD) procedures and wear an antistatic wrist strap.          |
| 4   | Wiring-related options, including cable shield brackets (applicable to T1 to T9 models), are available. |

## 5.8.2 Main Circuit Terminals

### T1 to T9 models

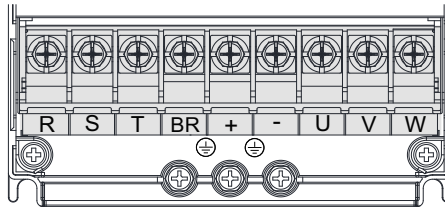

Figure 5-25 Layout of main circuit terminals of T1 to T4 models

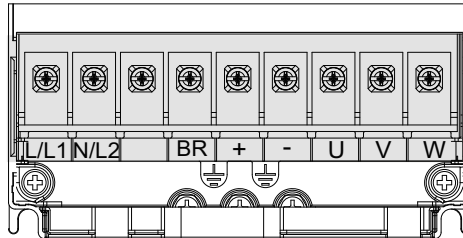

Figure 5-26 Layout of main circuit terminals of T2 models (single phase)

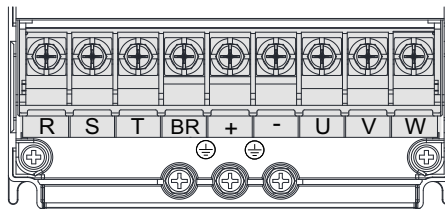

Figure 5-27 Layout of main circuit terminals of T1 to T4 models

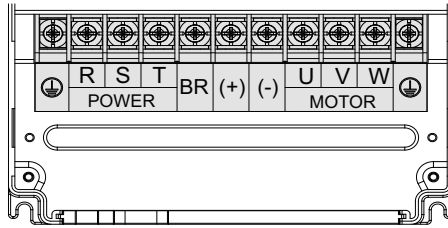

Figure 5-28 Layout of main circuit terminals of T5 to T8 models

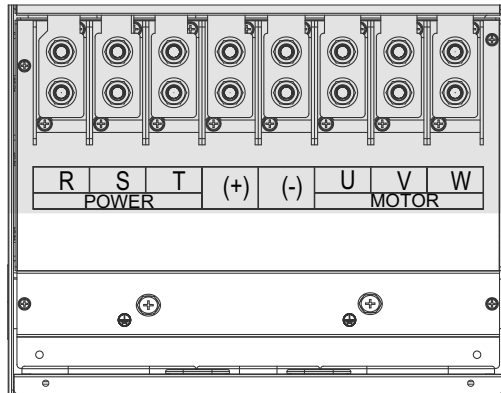



Figure 5-29 Layout of main circuit terminals of T9 models

Table 5-13 Main circuit terminals of T1 to T9 models

| Mark  | Name                                   | Function  |
|---|--|---|
| R, S, T   | Three-phase power input terminals      | Used to connect to a three-phase AC input power supply                                      |
| (+), (-)  | DC bus positive and negative terminals | Common DC busbar input, used to connect to an external braking unit for T9 models and above |
| (+), BR   | Braking resistor connection terminals  | Used to connect to the braking resistor of T8 models and below                              |
| U, V, W   | Output terminals                       | Used to connect to a three-phase motor  |
|  | Grounding (PE) terminal                | Used for protective grounding   |

**T10 to T12 models**

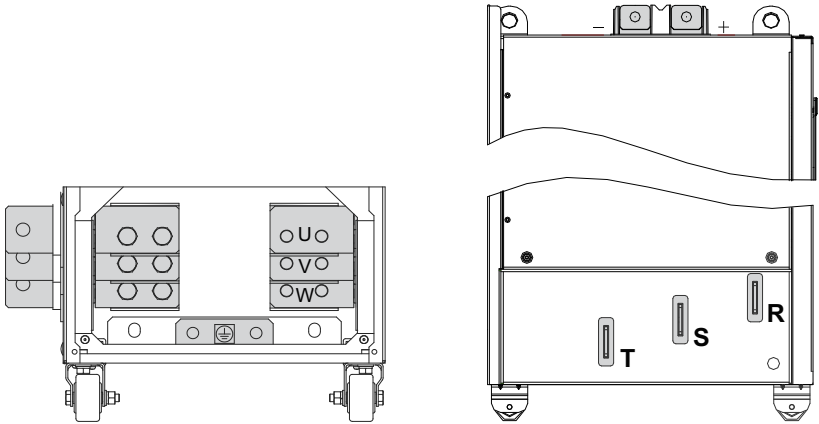



Figure 5-30 Layout of main circuit terminals of T10 to T12 models

Table 5-14 Main circuit terminals of T10 to T12 models

| Mark  | Name                                   | Function  |
|---|--|---|
| R, S, T   | Three-phase power input terminals      | Used to connect to a three-phase AC input power supply              |
| +, -  | DC bus positive and negative terminals | Common DC busbar input, used to connect to an external braking unit |
| U, V, W   | AC drive output terminals              | Used to connect to a three-phase motor                              |
|  | Grounding (PE) terminal                | Used for protective grounding                                       |

**5.8.3 Control Circuit Terminals**

"Table 5-16 " on page 72 describes control circuit terminals.

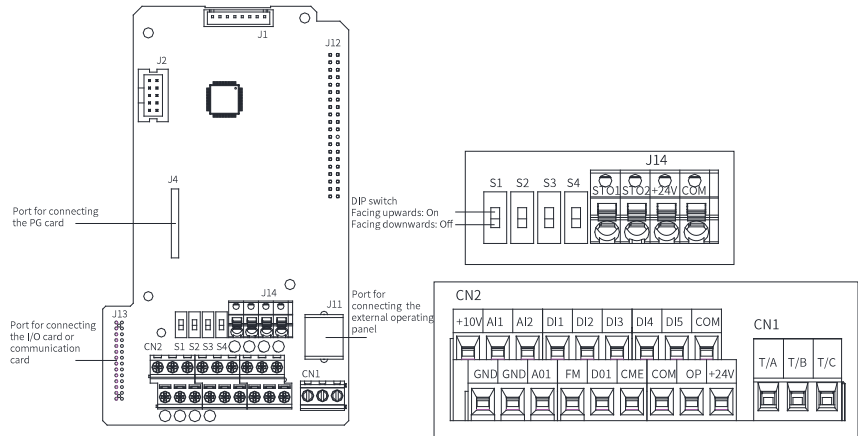

Figure 5-31 Control circuit terminals

Table 5–15 Description of control circuit terminals

| Type         | Mark     | Name                                     | Function Description  |
|--------------|----------|--|---|
| Power supply | +10V-GND | External +10 V power supply              | The terminal is used to provide +10 V power supply to an external unit with the maximum output current 10 mA.<br>Generally, it is used to power an external potentiometer with resistance ranging from 1 k $\Omega$ to 5 k $\Omega$ .   |
|              | +24V-COM | External +24 V power supply              | The terminal is used to provide +24 V power supply to an external unit. Generally, it is used to power DI/DO terminals and external sensors.<br>The maximum output current is 200 mA <sup>[Note 1]</sup> .  |
|              | OP       | Input terminal for external power supply | It is connected to +24V by default. To use an external signal to drive terminals DI1 to DI5, disconnect OP from +24V and connect it to an external power supply.  |
| Analog input | AI1-GND  | Analog input terminal 1                  | Input voltage range: –10 VDC to +10 VDC<br>Input impedance: 22 k $\Omega$   |
|              | AI2-GND  | Analog input terminal 2                  | The terminal supports voltage input (default), current input, and temperature input.<br>When used as voltage/current input, the terminal supports 0 V to 10 V, -10 V to +10 V, or 0 mA to 20 mA with the resolution 12-bit and the correction accuracy 0.3%.<br>The input impedance is 22 k $\Omega$ for voltage input and 500 $\Omega$ or 250 $\Omega$ for current input, which is set by S2 and S3 DIP switches <sup>Note [2]</sup> . |

| Type           | Mark    | Name                     | Function Description  |
|----------------|---------|--------------------------|---|
| Digital input  | DI1-OP  | Digital input 1          | Photocoupler isolation and bipolar input<br>Input impedance: 1.72 k $\Omega$<br>Voltage range for effective level input: 9 V to 30 V  |
|                | DI2-OP  | Digital input 2          |   |
|                | DI3-OP  | Digital input 3          |   |
|                | DI4-OP  | Digital input 4          |   |
|                | DI5-OP  | Digital input 5          | Besides features of DI1 to DI4, DI5 can also be used for high-speed pulse input.<br>Input impedance: 1.16 k $\Omega$<br>Maximum input frequency: 100 kHz<br>Operating voltage range: 15 V to 30 V   |
| Analog output  | AO1-GND | Analog output 1          | The DIP switch on the control board is used to determine voltage output (default) or current output.<br>Output voltage range: 0–10 V<br>Output current range: 0–20 mA   |
| Digital output | DO1-CME | Digital output 1         | Photocoupler isolation and bipolar open collector output<br>Output voltage range: 0–24 V<br>Output current range: 0–50 mA<br>Note that CME and COM are internally insulated, but are shorted externally by jumper as the factory settings. In this case, DO1 is driven by +24V. To drive DO1 by external power supply, remove the jumper between CME and COM. |
|                | FM-COM  | High-speed pulse output  | The terminal is set by F5-00 (FM terminal output selection). When the terminal is used for high-speed pulse output, the maximum frequency is 100 kHz. When the terminal is used for collector open output, it has the same specifications as DO1.   |
| Relay output   | T/A     | Common terminal          | Contact driving capacity:<br>250 VAC, 3 A, COS $\phi$ = 0.4<br>30 VDC, 1 A  |
|                | T/B     | Normally closed terminal |   |
|                | T/C     | Normally open terminal   |   |



| Type            | Mark | Name  | Function Description   |
|-----------------|------|---|--|
| Auxiliary ports | J13  | Expansion card terminal   | It is a 28-conductor terminal used to connect optional cards, such as bus cards                                |
|                 | J4   | PG card terminal  | It is used to connect the resolver, differential, and 23-bit encoders.   |
|                 | J11  | Port for external operating panel   | It is used to connect the LCD operating panel (SOP-20) and the LED operating panel (MDKE-10).                  |
| DIP switches    | S1   |  | For details, see <a href="#">"Table 5-16 Description of control circuit terminals 2" on page 72.</a>           |
|                 | S2   |   | For details, see <a href="#">"Table 5-16 Description of control circuit terminals 2" on page 72.</a>           |
|                 | S3   |   | For details, see <a href="#">"Table 5-16 Description of control circuit terminals 2" on page 72.</a>           |
|                 | S4   |   | It is used to determine whether AO1 supports the current mode. If S4 is closed, AO1 supports the current mode. |

Table 5-16 Description of control circuit terminals 2

| Mark | DIP Switch |     |     | Description  |
|------|------------|-----|-----|--|
|      | S1         | S2  | S3  |  |
| Name | OFF        | OFF | OFF | Voltage mode for AI2   |
|      | ON         | OFF | OFF | Temperature mode for AI2. The temperature sensor type can be set by F9-57. |
|      | OFF        | ON  | OFF | Current mode for AI2 with the input impedance 500 Ω                        |
|      | OFF        | ON  | ON  | Current mode for AI2 with the input impedance 250 Ω                        |

## Note

- [Note 1] If the ambient temperature exceeds 23°C, the output current must be derated by 1.8 mA for every additional 1°C. The maximum output current is 170 mA at 40°C. When OP and 24V are shorted, the maximum output current is calculated by the following formula: 170 mA minus current over the DI.
- [Note 2] Based on the maximum output voltage of the signal source, select 500 Ω or 250 Ω impedance. For example, if 500 Ω is selected, the maximum output voltage cannot be lower than 10 V so that AI2 can measure 20 mA current.

## 5.8.4 Inspection After Wiring

After wiring is completed, inspect the items in the following table and tick compliant items.

Table 5-17 Post-wiring inspection checklist

| No. | Item  | Compliance |
|-----|---|------------|
| 1   | The power supply input cables are connected to the R, S, and T terminals.   |            |
| 2   | The motor input cables are connected to the U, V, and W terminals.  |            |
| 3   | The dimensions of the main circuit cables meet the requirements.  |            |
| 4   | Heat-shrink tubes are applied to cable lug copper pipes and conductors of main circuit cables, and completely cover the cable conductors. |            |
| 5   | The motor output cable does not exceed 50 m. Otherwise, the carrier frequency needs to be reduced according to the setting of F0-15.      |            |
| 6   | The ground cables are connected correctly.  |            |
| 7   | The output terminals and control signal terminals are securely fastened.  |            |
| 8   | The braking resistor and braking unit (if used) are connected correctly and have proper resistance.                                       |            |
| 9   | The control circuit cables are shielded twisted pairs.  |            |
| 10  | Optional cards are connected correctly.   |            |

| No. | Item  | Compliance |
|-----|---|------------|
| 11  | The control circuit cables and main circuit power cables are routed separately. |            |
| 12  | There are no screws, gaskets, or exposed cables left inside the equipment.      |            |

### 5.8.5 Electrical Wiring Diagram

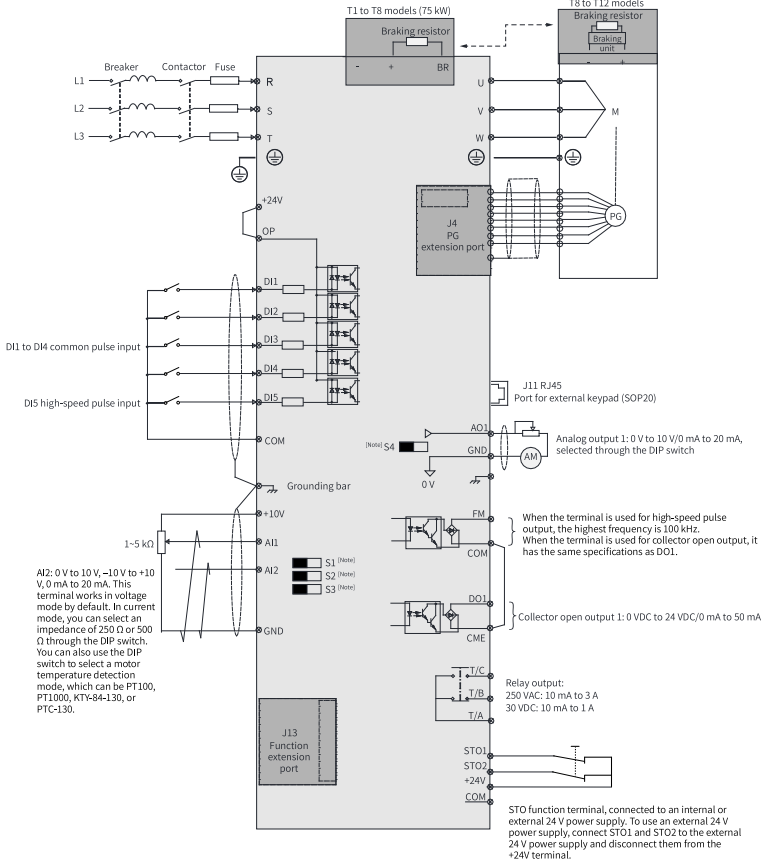

Figure 5-32 Standard wiring diagram

---

## Note

- For details on S1 to S4 DIP switches, see ["Table 5-15 Description of control circuit terminals" on page 70](#).
  - For three-phase 380 V to 480 V AC drives, 0.4 kW to 75 kW models differ from 90 kW to 450 kW models in the wiring detail marked by the double arrows in the figure.
  - For three-phase 200 V to 240 V AC drives, 0.4 kW to 37 kW models differ from 45 kW to 200 kW models in the wiring detail marked by the double arrows in the figure.
-

## 6 Wiring

### 6.1 Safety Cautions

Failure to comply with the following safety cautions for wiring may lead to equipment damage, physical injuries, severe accidents, or even death. Strictly follow the following safety cautions.



- Wiring must be carried out by professionals who have received necessary electrical training. Operations by non-professionals are strictly prohibited.
  - Before wiring, cut off all equipment power supplies. Wait for at least the time specified on the equipment warning label after power-off so that residual voltage can discharge safely. Measure the DC voltage on the main circuit to ensure that it is within the safe voltage range. Failure to comply may result in electric shock.
  - Do not perform wiring, remove the equipment cover, or touch the circuit board when power is on. Failure to comply will result in electric shock.
  - Make sure that the AC drive and related equipment are properly grounded. Failure to comply may result in electric shock.
  - Tighten terminal screws with tightening torque specified in this guide. Failure to comply may result in overheat and damage to the connection parts or even fire.
  - Never connect the input power cable to output terminals of the product or other equipment. Failure to comply may result in equipment damage or even fire.
  - After wiring, ensure that all cables are connected properly and no screws, washers, or exposed cables are left inside the equipment. Failure to comply may result in electric shock or equipment damage.
- 



- When connecting a drive to a motor, ensure consistency of terminal phase sequences between the drive and the motor to prevent reverse motor rotation.
  - Use cables with required diameter and shield. Properly ground one end of the shield if a shielded cable is used.
  - During wiring, follow the proper electrostatic discharge (ESD) procedures, and wear an antistatic wrist strap. Failure to comply will result in damage to internal equipment circuits.
  - Use shielded twisted pairs for the control circuit. Connect the shield to the grounding terminal of the equipment. Failure to comply will result in equipment malfunction.
-

## 6.2 STO Terminals (J14) and Wiring

### Terminal arrangement and definitions

The STO function is integrated in the control module, and its terminal arrangement and definitions are as follows.

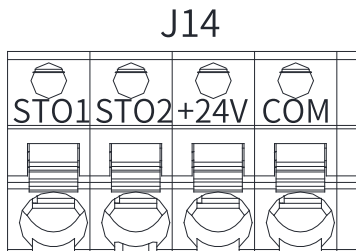

Figure 6-1 STO terminal arrangement

Table 6-1 STO terminals

| No. | Mark | Name   | Performance Requirements   |
|-----|------|--|--|
| 1   | STO1 | STO channel 1                                    | Internal connection: By default, STO1 and STO2 are connected to +24V by using a jumper bar upon factory delivery. External connection: STO1, STO2, and +24V can be connected to an external 24 V power supply. See the STO function for the detailed wiring. |
| 2   | STO2 | STO channel 2                                    |  |
| 3   | +24V | Positive power terminal for STO channels 1 and 2 |  |
| 4   | COM  | Power ground terminal of STO channels 1 and 2    |  |

### Electrical specifications and connections of input circuit

- Specifications

Table 6-2 Specifications

| Signal | Input State | Description                  |
|--------|-------------|------------------------------|
| STO1   | "1" or "H"  | The input signal is normal.  |
|        | "0" or "L"  | The STO function is enabled. |
| STO2   | "1" or "H"  | The input signal is normal.  |
|        | "0" or "L"  | The STO function is enabled. |

- Electrical characteristics

Table 6-3 Electrical characteristics of safety input signals

| Item                      | Characteristics       | Description                    |
|---------------------------|-----------------------|--------------------------------|
| Voltage range             | 24 VDC ( $\pm 15\%$ ) | -                              |
| Input current             | 4 mA (Typ.)           | This is the value per channel. |
| Standards of logic levels | "0" < 3 V, "1" > 15 V | -                              |
| Digital input impedance   | 5.63 k $\Omega$       | -                              |

- Connection example

1. Example connection of external 24 V

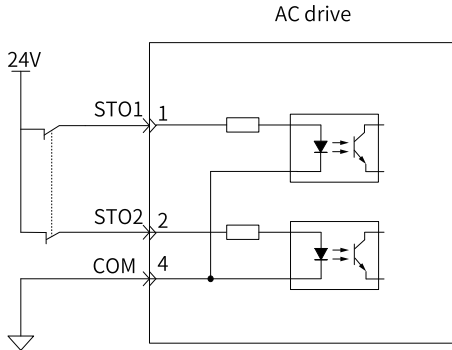

2. Example connection of internal 24 V

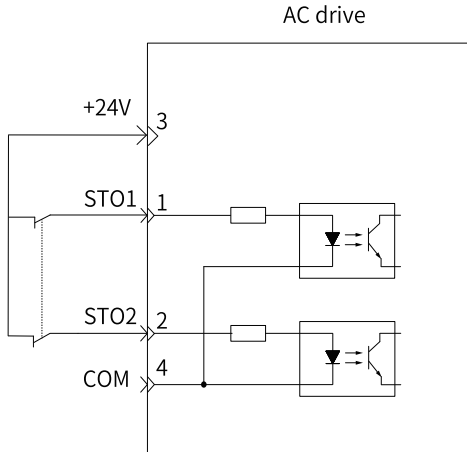

## EMC requirements

1. To avoid short circuit between adjacent conductors, use shielded cables and connect the shield to the protective bonding circuit. Alternatively, use flat cables and connect a grounding wire between adjacent signal conductors.
2. Double-shielded or single-shielded twisted multi-pair cable is recommended.
3. Fix and ground the cable shield using a piece of conductive metal.

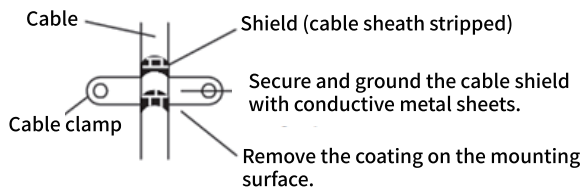

Figure 6-2 Cable clamp

4. The maximum allowable cable length between the AC drive and the activation switch is 30 m.



## 7 Safety Function

### 7.1 Safety Function Overview

The Safe Torque Off (STO) function immediately blocks the motor torque or power output in electronic mode according to input signals STO1 and STO2 from external devices. This function complies with stop category 0 in EN 60204-1.

If the motor is still rotating when the STO function is enabled, the motor will coast to a standstill.

### 7.2 Parameter Settings

The safety function module involves the following parameters.

| Para. No. | Name                 | Value Range                           | Default Value      | Description  |
|-----------|----------------------|---------------------------------------|--------------------|--|
| F9-79     | STO restoration mode | 0: Manual reset<br>1: Automatic reset | 1: Automatic reset | When both STO1 and STO2 are disconnected, the system enters the STO enabled state.<br>When STO1 and STO2 are restored, the system enters the servo ready state depending on the value of this parameter. |

## 7.3 STO

### 7.3.1 Overview

Safe Torque Off (STO) is a safety function that complies with IEC 61800-5-2:2016. This AC drive is integrated with the STO function. After the STO function is enabled, the AC drive switches off the servo ready (RDY) signal and enters the safe state. At the same time, the drive control signal of the power semiconductor is blocked and the input motor current is cut off to prevent the AC drive from generating the torque at the motor shaft end to make the motor stop operating.

The STO function blocks the output of PWM signals to the power layer of the AC drive through external redundant hardware terminals STO1 and STO2, preventing the movement of the motor. The two +24 VDC signals must be active (high level) to enable normal operation of the AC drive. If either or both of them are at low level simultaneously, the PWM signal will be blocked.

### 7.3.2 Triggering STO in Local Mode

To correctly use the input signals of the safety module, ensure that the system is correctly connected. If either the STO1 or STO2 signal is disconnected, the system enters the safe state.

Table 7-1 STO function list

| STO2 Input | STO1 Input | PWM Status | System Status                      | Reset  |
|------------|------------|------------|------------------------------------|--|
| H          | H          | Normal     | Normal                             | -  |
| H          | L          | Blocked    | Error Err47.2, inconsistent inputs | Manual reset   |
| L          | H          | Blocked    | Error Err47.2, inconsistent inputs | Manual reset   |
| L          | L          | Blocked    | STO enabled                        | Automatic or manual reset, depending on the value of F9-79 |

### Note

- H (1): The corresponding input is connected to the 24 V voltage.
- L (0): The corresponding input is disconnected from the 24 V voltage.

### 7.3.3 Time Sequence Diagram

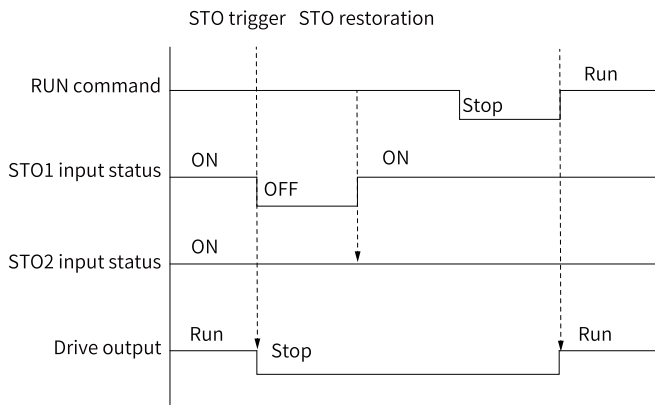

Figure 7-1 Safety function (STO1 trigger changed to OFF)

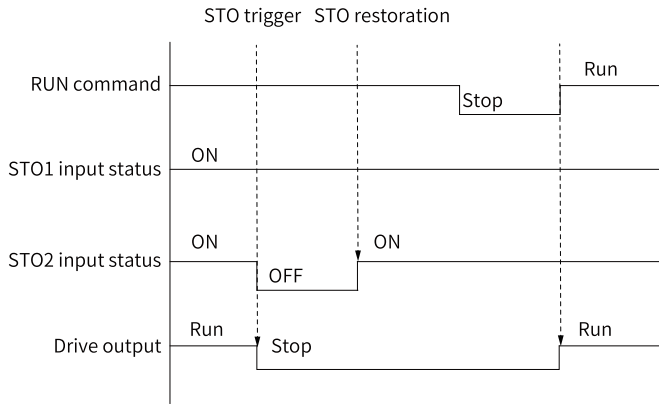

Figure 7-2 Safety function (STO2 trigger changed to OFF)

## 8 Commissioning, Operation, and Maintenance

### 8.1 Commissioning, Operation, and Maintenance

#### Basic requirements

- Technical staff must be trained to understand the requirements and principles of designing and operating safety-related systems.
- Execution and maintenance personnel must be trained on the requirements and principles of designing and operating safety-related systems.
- Operators must be trained to understand the requirements and principles of designing and operating safety-related systems.
- The safety-related circuit on the control board that fails to operate must be replaced with a new one as it is not repairable.

#### Commissioning checklist

IEC 61508, EN IEC 62061, and EN ISO 13849 require the equipment to pass acceptance tests to verify the operation of safety functions. Acceptance testing must be performed at the following stages:

- Initial startup of the safety functions
- After any changes related to safety functions (wiring, assembly, settings, or other related operations)
- After any maintenance work related to safety functions is completed

Acceptance testing of safety functions must be performed by personnel with safety function expertise and must be documented and signed by the testers. Technical staff and operation, maintenance, and repair personnel must be trained to understand the requirements and principles of designing and operating safety-related systems.

The signed acceptance test report must be kept in the log of the equipment. The report shall include documentation of start-up activities and test results, fault reports, and troubleshooting records. Any new acceptance tests due to changes or maintenance shall be recorded in the log.

#### Verification and confirmation

- **Content**

The following describes how to verify and confirm implemented safety functions.

Document proofs will be available for verification and confirmation to verify that the implementation meets specified safety requirements.

- **SIL/PL level compliance**

Verification of the functional safety system proves and confirms that the implemented safety system meets the requirements defined for each stage.

The required SIL/PL level of an implemented system is verified by using the specific safety calculator software.

- **Verification program**

Inovance ensures that all the required safety functions are properly verified and confirmed.



- Never assume that the system is safe before verifying all the safety functions.
  - Perform acceptance test for every safety function.
- 

The acceptance test must be performed by using the following startup checklist at the following stages:

- Initial startup of the safety functions
- After any changes related to safety functions (wiring, assembly, settings, or other related operations)
- After any maintenance work related to safety functions is completed  
Acceptance testing must include the following steps at least:
  1. Develop an acceptance test plan.
  2. Test whether all the entrusted functions can operate properly.
  3. Test whether all the inputs in use can operate properly.
  4. Test whether all the outputs in use can operate properly.
  5. Record all the executed acceptance tests.
  6. Ask the testers to sign and archive the acceptance test report for further reference.

- **Acceptance test report**

You must store the signed acceptance test report in the log of the equipment. According to relevant standards, the report must contain the following items:

- Safety program description (including one diagram)
- Description and revision of safety components used in the safety program
- List of all the safety functions used in the safety program
- List of all safety-related parameters and their values (list of all parameters not related to safety functions if STO is enabled on the drive)
- Documentation of startup activities, fault reports, and fault solutions
- Confirmation of the test result, checksum, test date, and tester for each safety function

- **Safety function verification**

Once complete configuration and cabling are completed for the safety functions and the startup safety check is completed, execute the following functional testing program for each safety function:

- Set the system to the operational state when a safety function is requested.
- Ensure that the confirmation method is set to a proper program (such as manual or automatic confirmation).
- Request to activate a safety function using the specified triggering device.
- Verify that all the required functions are implemented.
- Record the test results in the acceptance test report.
- Sign and archive the acceptance test report.

● **Acceptance test checklist**

Table 8-1 Acceptance test checklist

| Step | Action  | Result |
|------|---|--------|
| 1    | Ensure that the AC drive runs and stops freely during commissioning.  |        |
| 2    | Stop the AC drive (if under operation), switch the input power supply off, and isolate the drive from the power cable through a disconnecter. |        |
| 3    | Check the STO circuit connections (inputs of STO1 and STO2 and 24 V terminals) based on the circuit diagram.                                  |        |
| 4    | Check whether the shield of the STO input cable is grounded to the drive frame.   |        |

| Step | Action  | Result |
|------|---|--------|
| 5    | Switch the disconnecter off and then switch the input power supply on.  |        |
|      | Test the STO1 or STO2 signal when the system stops:<br>1. Awake the STO function by disconnecting both the STO1 and STO2 signals. Check whether the AC drive enters the STO activated state and displays STO.<br>2. Send a start command to the AC drive. Ensure that the AC drive does not respond and the motor stays standstill.<br>3. The STO1 and STO2 channel signals are restored and the system is restored to the normal state according to the setting of F9-79. Run the ON/RUN command on the AC drive, and check whether the motor operates properly. |        |
|      | Test the STO1 channel signal when the system stops:<br>1. Awake the STO function by disconnecting the STO1 channel input signal (low state or open-circuit). Check whether the AC drive displays the fault code "E047.2".<br>2. Send a start command to the AC drive. Ensure that the AC drive does not respond and the motor stays standstill.   |        |
|      | The STO1 channel signal is restored and the fault is cleared. Run the ON/RUN command on the AC drive, and check whether the motor operates properly.  |        |
|      | Test the STO2 channel signal when the system stops:<br>1. Awake the STO function by disconnecting the STO2 channel input signal (low state or open-circuit). Check whether the AC drive displays the fault code "E047.2".<br>2. Send a start command to the AC drive. Ensure that the AC drive does not respond and the motor stays standstill.   |        |
|      | The STO2 channel signal is restored and the fault is cleared. Run the ON/RUN command on the AC drive, and check whether the motor operates properly.  |        |

| Step | Action   | Result |
|------|--|--------|
| 6    | <p>Test the STO1 or STO2 signal when the system is under operation:</p> <ol style="list-style-type: none"> <li>1. Awake the STO function by disconnecting both the STO1 and STO2 signals. Check whether the AC drive enters the STO activated state and displays STO. In this case, the AC drive immediately stops output. The motor then coasts to stop based on the mechanical inertia.</li> <li>2. Send a start command to the AC drive. Ensure that the AC drive does not respond and the motor stays standstill.</li> <li>3. The STO1 and STO2 channel signals are restored and the system is restored to the normal state according to the setting of F9-79. Run the ON/RUN command on the AC drive, and check whether the motor operates properly.</li> </ol> |        |
|      | <p>Test the STO1 channel signal when the system is under operation:</p> <ol style="list-style-type: none"> <li>1. Start the AC drive and ensure that the motor operates properly.</li> <li>2. Awake the STO function by disconnecting the STO1 channel signal. Check whether the AC drive displays the fault code "E047.2". In this case, the AC drive immediately stops output. The motor then coasts to stop based on the mechanical inertia.</li> </ol>   |        |
|      | <p>The STO1 channel signal is restored and the fault is cleared. Run the ON/RUN command on the AC drive, and check whether the motor operates properly.</p>  |        |
|      | <p>Test the STO2 channel signal when the system is under operation:</p> <ol style="list-style-type: none"> <li>1. Start the AC drive and ensure that the motor operates properly.</li> <li>2. Awake the STO function by disconnecting the STO2 channel signal. Check whether the AC drive displays the fault code "E047.2". In this case, the AC drive immediately stops output. The motor then coasts to stop based on the mechanical inertia.</li> </ol>   |        |
|      | <p>The STO2 channel signal is restored and the fault is cleared. Run the ON/RUN command on the AC drive, and check whether the motor operates properly.</p>  |        |
| 7    | <p>Record and sign the acceptance test report to prove that the safety function is safe and the equipment can be put into operation.</p>   |        |



## 9 Maintenance

### 9.1 Routine Maintenance

#### 9.1.1 Daily Inspection Items

Influence of ambient temperature, humidity, dust, and vibration will cause aging of components in the device, resulting in potential faults or shortened service life of the device. Therefore, carry out daily and periodic maintenance. More frequent maintenance is required if the device is used in harsh environments, including the following:

- High ambient temperature
- Frequent start and stop
- Fluctuations in the AC power supply or load
- Excessive vibrations or shocks
- Dust, metal dust, hydrochloric acid, and other corrosive articles

Check the following items daily to avoid deterioration in performance or product damage. Print the checklist and sign the "Checked" column after each inspection.

| Item                     | Description  | Solution   | Checked |
|--------------------------|--|--|---------|
| Motor                    | Check whether abnormal sounds and vibration occur on the motor.      | <ul style="list-style-type: none"> <li>● Check whether the mechanical connection is normal.</li> <li>● Check whether phase loss occurs on the motor.</li> <li>● Check whether retaining screws of the motor are tightened.</li> </ul>  |         |
| Cooling fan              | Check whether the cooling fans of the AC drive and motor are normal. | <ul style="list-style-type: none"> <li>● Check whether the cooling fan of the AC drive is normal.</li> <li>● Check whether the cooling fan of the motor is normal.</li> <li>● Check whether the ventilation is clogged.</li> <li>● Check whether the ambient temperature is within the permissible range.</li> </ul> |         |
| Installation environment | Check whether the cabinet and cable ducts are normal.                | <ul style="list-style-type: none"> <li>● Check for insulation damage of input and output cables.</li> <li>● Check for the mounting bracket vibration.</li> <li>● Check whether copper busbars and cable terminals become loose or get corroded.</li> </ul>   |         |

| Item          | Description  | Solution   | Checked |
|---------------|--|--|---------|
| Load          | Check whether the running current of the AC drive exceeds the rated current of the AC drive and motor.     | <ul style="list-style-type: none"> <li>● Check whether the motor parameters are set correctly.</li> <li>● Check whether the motor is overloaded.</li> <li>● Check whether the mechanical vibration is severe (allowed value: &lt; 0.6 g).</li> </ul> |         |
| Input voltage | Check whether the voltage of the main circuit power supply and the control circuit power supply is normal. | <ul style="list-style-type: none"> <li>● Check whether the input voltage is within the permissible range.</li> <li>● Check whether startup of heavy load exists.</li> </ul>  |         |

### 9.1.2 List of Periodic Inspection Items

Check the items listed in the following table every one or two years, dependent on actual use and work environment of the product. Periodic maintenance helps detect product function deterioration and damage.

Copy this checklist and sign the "Checked" column after each inspection.



To prevent electric shock, do not perform inspection or wiring with power ON. Switch off the power supplies of all the devices before wiring or maintenance. Wait for at least a period of time specified on the product warning label before further operations because residual voltage still exists after power-off. Measure the DC voltage in the main circuit to ensure the DC voltage is within the safe range; failure to comply may result in electric shock.

| Inspection Item | Description   | Solution   | Checked |
|-----------------|---|--|---------|
| General         | Check for waste, dirt, and dust on the surface of the AC drive.   | <ul style="list-style-type: none"> <li>● Check whether the controller cabinet is powered off.</li> <li>● Use a vacuum cleaner to suck up waste and dust to avoid direct touching.</li> <li>● Wipe stubborn stains with alcohol and do not operate the AC drive until the alcohol completely evaporates.</li> </ul> |         |
| Cables          | <ul style="list-style-type: none"> <li>● Check power cables and connections for discoloration.</li> <li>● Check wiring insulation for aging or wear.</li> </ul> | <ul style="list-style-type: none"> <li>● Replace cracked cables.</li> <li>● Replace damaged terminals.</li> </ul>  |         |

| Inspection Item                                      | Description  | Solution   | Checked |
|--|--|--|---------|
| Peripheral devices such as electromagnetic contactor | <ul style="list-style-type: none"> <li>• Check devices for loose connection and abnormal noise during operation.</li> <li>• Check peripheral devices for short circuit, water stains, swelling, and cracks.</li> </ul> | Replace abnormal peripheral devices.   |         |
| Ventilation  | <ul style="list-style-type: none"> <li>• Check whether ventilation and heatsink are clogged.</li> <li>• Check whether the fan is damaged.</li> </ul>   | <ul style="list-style-type: none"> <li>• Clean the ventilation.</li> <li>• Replace the fan.</li> </ul>   |         |
| Control circuit                                      | <ul style="list-style-type: none"> <li>• Check control elements for loose contact.</li> <li>• Check for loose terminal screws.</li> <li>• Check control cables for cracked insulation.</li> </ul>                      | <ul style="list-style-type: none"> <li>• Clear foreign matters on the surface of control cables and terminals.</li> <li>• Replace damaged or corroded control cables.</li> </ul> |         |

## 9.2 Main Circuit Insulation Test



Do not conduct high voltage (> 500 V) tests, which are already done before delivery.

Before testing, remove the VDR screw and disconnect the VDR.

Before measuring insulation resistance with a megameter (500 VDC megameter recommended), disconnect the main circuit from the AC drive first. Do not measure the control circuit insulation resistance with an insulation resistance meter.

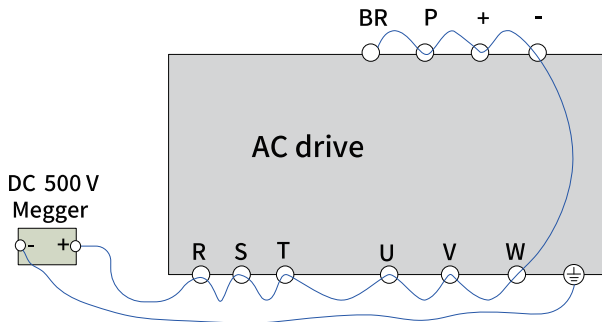

The insulation resistance measured must be greater than 5 MΩ.



Disconnect the optional grounding screw of VDR before any voltage resistance test; failure to comply may result in test failure.

## 9.3 Replacement of Quick-Wear Parts

### 9.3.1 Service Life of Quick-Wear Parts

Quick-wear parts of the AC drive include the cooling fan and electrolytic capacitor. Their lifetime is related to the operating environment and maintenance. Generally, the service life is as follows.

| Component  | Service Life <sup>[Note]</sup> |
|--|--------------------------------|
| Fan  | ≥ 5 years                      |
| Electrolytic capacitor   | ≥ 5 years                      |
| Note:<br>The standard service life of a device is the expected lifetime when the device is used in the following conditions. You can determine when to replace your devices based on the actual operating time.<br>Ambient temperature: 40°C<br>Load rate: 80%<br>Operating rate: 24 hours per day |                                |

### 9.3.2 Replacing the Cooling Fan

#### Quantity of cooling fans

- Possible damage causes: bearing worn and blade aging.
- Diagnosis: cracks on the blade, abnormal vibration noise upon startup, and abnormal running of fan blades
- Replacement: Press the snap-fit joint on the fan plastic cover and pull the fan outward. After replacement, check that the air flows upwards.

Table 9-1 Quantity of cooling fans

| Model  | Quantity |
|--|----------|
| T1 (0.4 kW to 1.1 kW)                                  | /        |
| T1 (1.5 kW to 3.0 kW)<br>T2<br>T3 (7.5 kW)<br>T5 to T7 | 1        |
| T3 (11 kW)<br>T4<br>T8 to T10                          | 2        |
| T11 to T12   | 3        |

## Removing and Installing Cooling Fans of T1 to T6 Models

### Removing

1. Press the snap-fit joint of the fan cover and remove the cover.

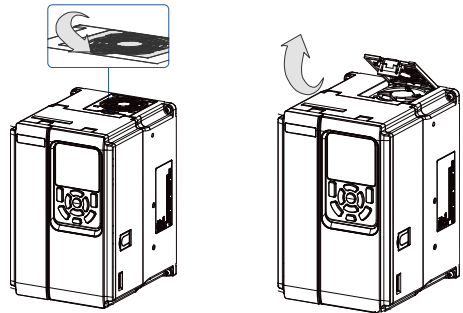

2. Pull the fan upward and disconnect the plug of the power cable.

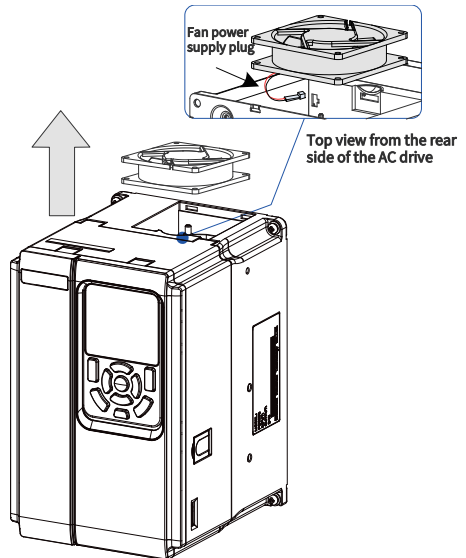

## Installing

### Note

Install the fan in reverse order of removal. Pay attention to the fan direction.

1. Plug the power cable plug of the fan into the fan socket.

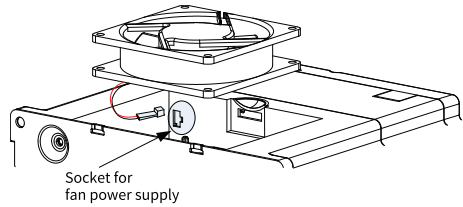

2. Align the four fixing holes at the bottom of the fan with the positioning pins on the drive to place the fan.

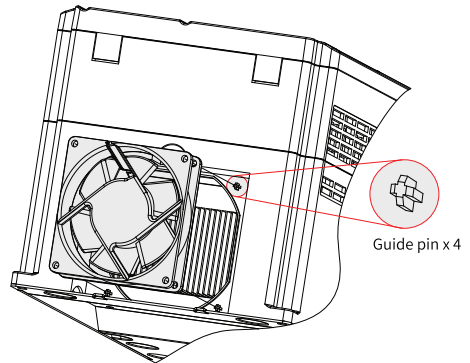

3. Insert the two snap-fit joints into the groove and then snap them into the groove.

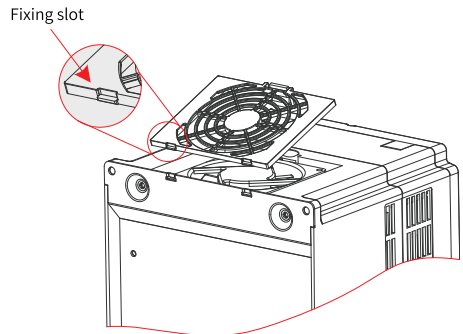

4. After replacement, check that the air flows upwards.
- 

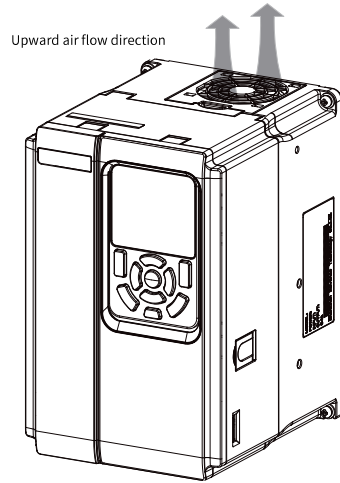

## Removing and installing cooling fans of T7 to T9 Models

---

### **Note**

The quantity and layout of cooling fans vary with models, but the fans can be removed or installed in the same way.

---

### **Removing**

1. Disconnect the power cable plug of the fan from the fan socket (top view).
- 

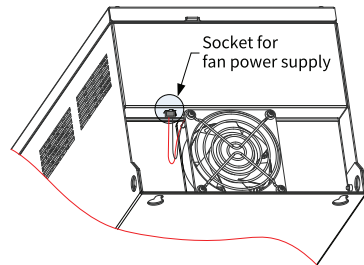

2. Use a screwdriver to remove the four fixing screws from the fan cover.
- 

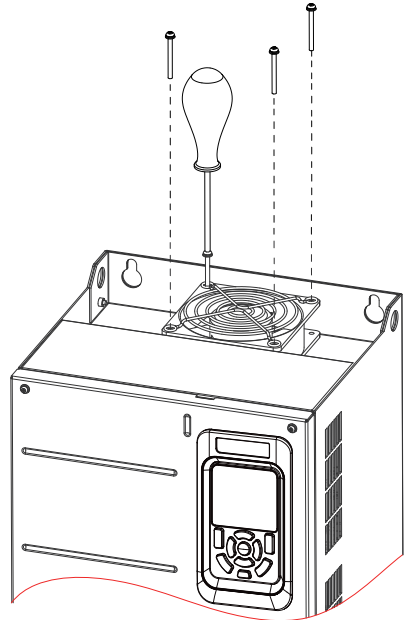

3. Remove the fan cover and fan from the AC drive.
- 

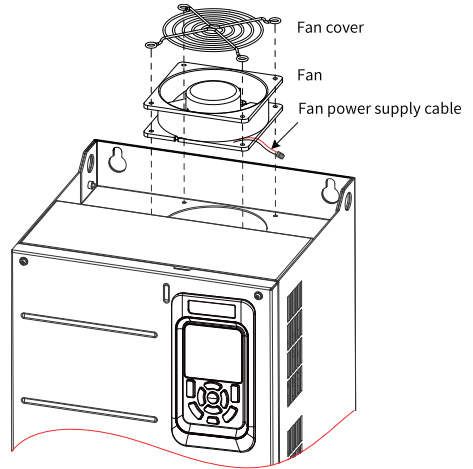

## Installing

1. Install the fan in reverse order of removal and ensure the correct direction of the fan.
-



2. Align the fixing holes of the fan cover and the fan with those on the AC drive to install them.
- 

3. After replacement, check that the air flows upwards.
- 

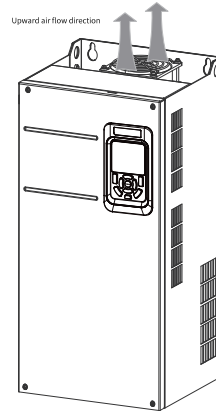

## Removing and installing cooling fans of T10 to T12 models

### Removing

1. Remove the six fixing screws from the cover, hold the cover with two hands, and lift it along the arrow direction to remove it.
- 

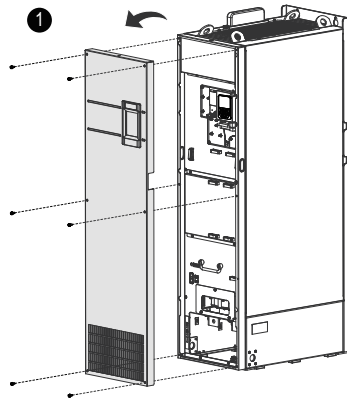

2. Disconnect the power cable plug of all fans. Remove the three fixing screws from the fan box and pull out the fan box in the direction of arrow.
- 

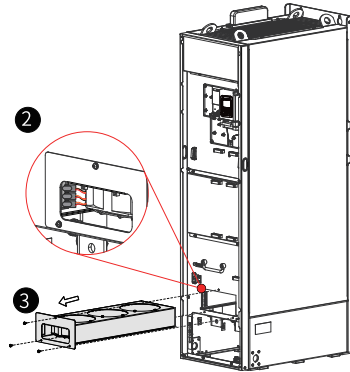

3. Remove the four fixing screws from each fan cover and remove the fan.
- 

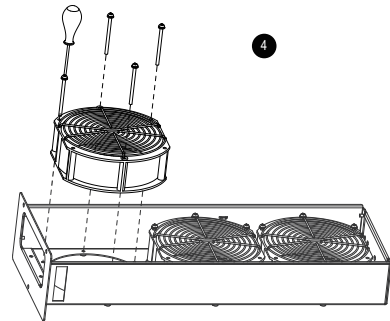

## Installing

1. Install the fan in reverse order of removal and ensure the correct direction of the fan.
- 
2. Align the fan box with the rail and push it into the AC drive.
-

3. Connect the power cable plug of the fan and fasten the fan box. After replacement, check that the air flows upwards.
- 

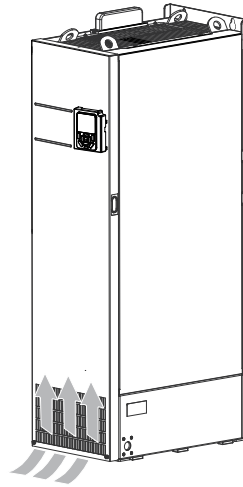

### 9.3.3 Replacing the Filter Electrolytic Capacitor

- Possible damage causes: poor input power supply, high ambient temperature, frequent load jumping, and electrolyte aging
- Determination criteria: liquid leakage, protruded safety valve, and measurements of electrostatic capacitance and insulation resistance
- Replacement: To avoid damage to other components inside the AC drive, contact Inovance for replacing the filter electrolytic capacitor.

## 9.4 Storage and Warranty

### Storage

To store the AC drive properly, observe the following:

- For storage, pack the AC drive with the original packing box provided by Inovance.
- Avoid exposing the AC drive to moisture, high temperature, or outdoor direct sunlight for an extended period.
- The electrolytic capacitor will deteriorate after the AC drive is stored for a long time. Therefore, energize the AC drive once for at least five hours every six months. Use a regulator to increase the input voltage gradually to the rated value. For any problem, contact Inovance.

### Warranty

Free warranty only applies to the AC drive itself.

Inovance provides an 18-month free warranty to the equipment from the date of manufacturing (subject to the barcode on the AC drive or contract if any) for failures

or damages under normal use conditions. When the warranty period expires, a reasonable repair fee will be charged.

Within the 18-month warranty period, a reasonable repair fee will be charged for damages caused by the following:

- Operations not following the user instructions
- Fire, flood, or abnormal voltage
- Using the AC drive for any non-recommended function
- Using the AC drive beyond recommended specifications
- Force majeure (natural disaster, earthquake, and lightning strike) and secondary damages

The repair fee is charged according to Inovance's standardized price list. If there is an agreement, the agreement prevails.

# 10 Troubleshooting

## 10.1 Troubleshooting

See the following table for the causes and solutions of failures. If the problem cannot be solved through the solutions in the following table, contact Inovance for technical support.

Table 10-1 Fault causes and solutions

| Fault Code | Possible Cause   | Solution  |
|------------|--|---|
| STO        | STO1 or STO2 is not connected to the 24 V input voltage.                       | Ensure that both STO1 and STO2 are connected to the 24 V input voltage signal.  |
| E47.02     | The input states of STO1 and STO2 are inconsistent.                            | 1. Ensure that STO1 and STO2 voltage disconnection requests are triggered at the same time.<br>2. The input circuit is abnormal. After disconnecting the 24 V signal, an STO input signal is still in "High" state. In this case, contact Inovance for technical support. |
| E47.03     | The OV/UV of the 5 V power supply or UV of the 1.2 V power supply is detected. | Recover the power supply to normal state. Contact Inovance for technical support.   |
| E47.04     | The STO input circuit is abnormal.   | To fix the input circuit fault, contact Inovance for technical Support.   |
| E47.05     | The STO pre-charge circuit is abnormal.  | To fix the pre-charge circuit fault, contact Inovance for technical support.  |
| E47.07     | The flash detection is abnormal.   | Contact Inovance for technical support.   |
| E47.08     | The RAM detection is abnormal.   | Contact Inovance for technical support.   |



19011795A02

---

Copyright © Shenzhen Inovance Technology Co., Ltd.

---

**Shenzhen Inovance Technology Co., Ltd.**

[www.inovance.com](http://www.inovance.com)

---

**Add.:** Inovance Headquarters Tower, High-tech Industrial  
Park, Guanlan Street, Longhua New District, Shenzhen

**Tel:** (0755) 2979 9595      **Fax:** (0755) 2961 9897

---

**Suzhou Inovance Technology Co., Ltd.**

[www.inovance.com](http://www.inovance.com)

---

**Add.:** No. 16 Youxiang Road, Yuexi Town,  
Wuzhong District, Suzhou 215104, P.R. China

**Tel:** (0512) 6637 6666      **Fax:** (0512) 6285 6720

**Name and address of the person authorized to compile the technical file:**

**Inovance Technology Europe GmbH**

**Add.:** Gottlieb-Daimler-Straße 17/2, 74385 Pleidelsheim,  
Germany

**Position:** Engineering Services Manager

**Name:** Hans-Peter Abel      **Tel :** +49 (7144) 899-328